

ON  
R  
NG  
ADE  
SY



**CONVERTING  
MADE EASY**

[www.gm.dk](http://www.gm.dk)

# MORE THAN FOUR DECADES IN FINISHING

**Grafisk Maskinfabrik**, commonly known as **GM**, has provided converting solutions for the label industry for four decades. GM is a family-owned company, building on the traditional values of Danish design and solid craftsmanship with a backbone of 40 years of experience in providing solutions for customers in the label industry worldwide. The company is firmly grounded by knowledge and insight of the graphic business and continuously works towards the goal of **“Making Converting Easy”**.

Even though GM is a global player on the labelling market with agents worldwide and offices in Denmark, United Kingdom, Italy, US and Chile, all machines are developed, designed, produced and assembled in the small town of Birkerød just outside Copenhagen. The core product and flagship of the company is the DC platform, a converting portfolio that comes in four sizes with a vast number of options and can run either inline or offline with your press of choice.

<b>DIE CUTTERS &amp; FINISHING</b>	<b>4</b>
DC350 / DC550	6
DC330MINI	8
DC330MINIflex	10
DC330NANO	12
<b>DC OPTIONS</b>	<b>13</b>
GM SmartView, GM SmartSlit, GM SmartLam, GM SmartLoad	13
GM SmartStrip, GM SmartTurret, GM Semi Automatic Turret, GM SmartCrush	14
GM SmartChill - New Chilling Solution, GM Buffers	15
<b>LASER</b>	<b>16</b>
LC330 & DC330Hybrid	18
<b>EMBELLISHMENT</b>	<b>20</b>
330FB Premium Wine Label Line	22
HOTFB330 Standalone Hot Foil	24
SC330 Precision Screen Printer	25
<b>INSPECTION &amp; SLITTER REWINDERS</b>	<b>26</b>
SR350 Slitter Rewinder with Inspection	28
IR330 Inspection Rewinder	29
Other Inspection Rewinders	30
<b>LAMINATORS</b>	<b>31</b>
HL500 Hot Laminator	32
LA330 Advanced Laminator	33
<b>COATERS</b>	<b>34</b>
IC30 Inline Coating	35
EB30 Integrated Coating Module with ebeam Curing	36
UC500L Coater with Lamination and Flexo Varnish	37
UC500 Universal Coating and Priming Unit	38
DS330 Inline Duplex Coating	39
<b>CARDBOARD FINISHING</b>	<b>40</b>
XP500 Cardboard Finishing	41
<b>SHEETERS</b>	<b>42</b>
ETV330/515 High Speed Sheeter	43
HS30 High Speed Rotary Sheeter	44
<b>CORE CUTTERS</b>	<b>45</b>
PNT160S & P160LC	46
<b>ROLL HANDLING EQUIPMENT</b>	<b>47</b>
KU200, KU350DHF, RL Roll Turner	48
KU350DHFM, KU600, RL Roll Lifter	49
<b>WINDERS</b>	<b>50</b>
LRW500, LUW500	51
<b>WASTE REMOVAL AND SHREDDERS UNITS</b>	<b>52</b>
GR80, GR80K, SU3	53
<b>SOLAR</b>	<b>54</b>
SOLAR Coating Platform	56
LRN15M Mini Roll to Roll	57
<b>CONFIGURATION EXAMPLES</b>	<b>58</b>

**DIE  
CUTT  
&  
FINI  
SHING**

ERS

G

# DC350 / 550

## Fully Integrated Converting Line for Labels

- *Maximum modularity*
- *Automated production*
- *Non-stop finishing with the new SmartTurret*
- *Open platform for Hotfoil and Screen*
- *Low energy consumption*
- *Low level of waste*
- *Online support and remote diagnostics*
- *Industry 4.0 ready*

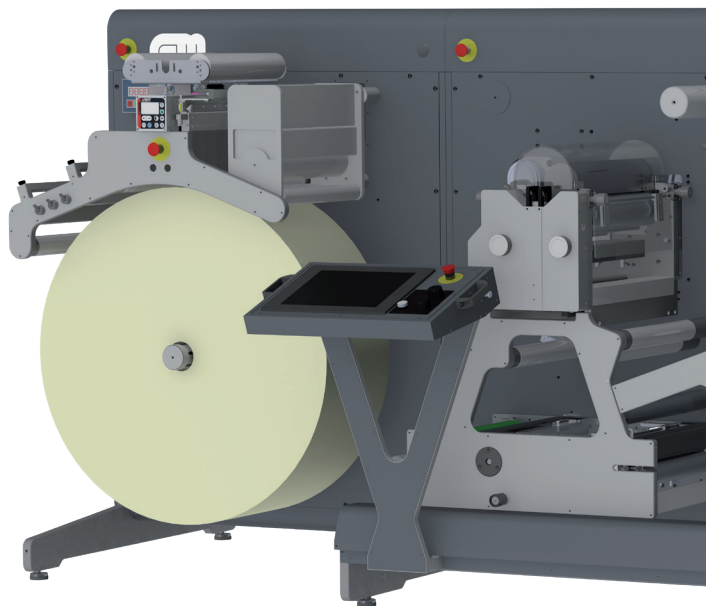

Specifications	Metric	Imperial
Web width	50 - 350 mm	2 - 14"
Substrate thickness	50 - 200 µm	2 - 8 pt.
<b>Die Station</b>		
Semi-rotary speed	80 m/min	262 ft/min
Full-rotary speed	90 m/min	295 ft/min
Die plate size	50,8 - 558,8 mm	2 - 22"
<b>Unwinder</b>		
Diameter max	1000 mm	39.4"
Core diameter	76,2 mm	3"
<b>Rewinder</b>		
Diameter max on dual shaft	700 mm	27.5"
Diameter max on Turret	450 mm	17.5"
Standard core diameter	76,2 mm	3"
Waste matrix rewinder diameter	up to 800 mm on request	up to 31.5" on request
<b>GM SMARTFlexo Station - flower style, semi-rotary</b>		
Print cylinder size	228 - 482,5 mm	9 - 19"
Spot varnish with digital sensor register control and slow run included		
<b>Slitting Station</b>		
Knife type	Pneumatic crush, smart crush shear or AutoSlitting	
Minimum distance crush	12,7 mm	0.5"
Minimum distance shear	10	0.4"
Minimum distance autoknife	20	0.8"
Dimensions (WxDxH)	5,9 x 2,3 x 1,7 m	19.4 x 7.4 x 5.5 ft

\*Please contact us for DC550 specifications details

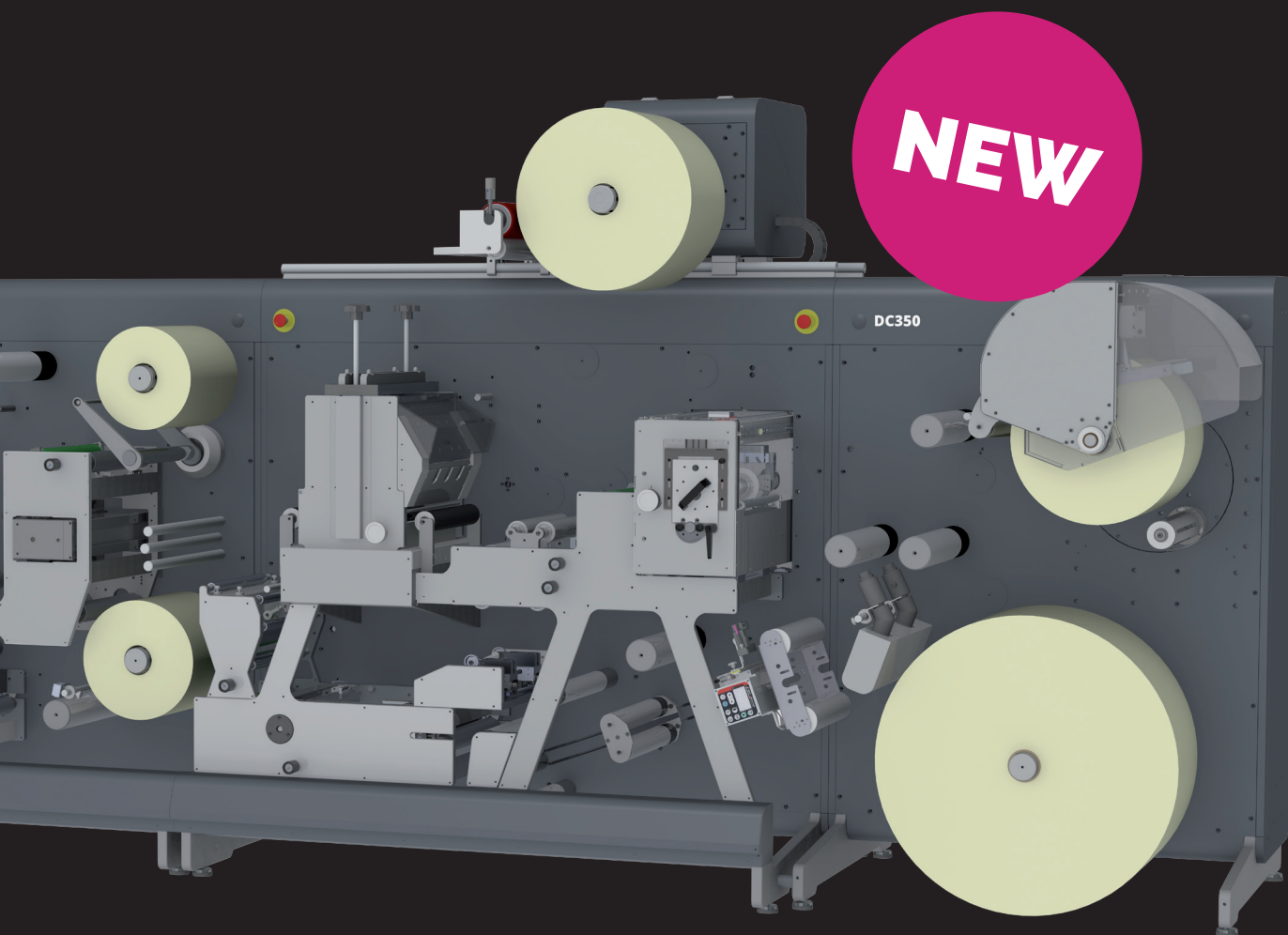

**The NEW premium finishing line - the DC350.** Get the best in fast and automated converting. Build with semi-rotation in varnish and die cutting as standard. Upgrade with value options like multilayer labels, Laser die cutter, Hot Foil and Screen Print unit.

**Take your factory to the industry 4.0 level.** This machine combines development work with proven product features. High speed, semi-rotating varnish, job automation and finally inline compatible with all major digital presses. The **NEW DC350** sets a new benchmark in the label world.

- Platform fully modular for added flexibility
- Jumbo roll unwinder with integrated roll lift
- GM SMARTSemi-Rotary Flexo Station
- GM SmartLoading (NEW) option – an automatic flexible die plate changing system to reduce changeover times and to ensure an accurate die mounting in seconds – every time.
- SmartGap electronic semi-rotary die cut option
- GM SmartStripping (NEW) option – a remarkable waste matrix stripping and rewinding system with servo-controlled tension. The waste matrix is peeled off around an idle rubber roller and immediately transferred to the rewinder. It ensures trouble-free operation even while converting delicate substrates and complex label shapes at high speed.
- GM SmartLam Multilayer option
- GM Automatic Slitting Station option
- GM SmartCrush (NEW) option – an ultra-quick set knives system, allowing fast and precise setting of each crush knife – also while running.
- GM SmartAutomatic Turret (NEW) option
- Hot Foil and Screen Print options
- STORCK rotary screen option for tactile labels
- Web-advance for fast roll change
- Runs inline with GM flat bed hotfoil
- Fully customizable and upgradeable
- Easy web access and maintenance

# DC330MINI

## Smart Compact Converting

- *The fastest small footprint machine in the market - "Swiss Army knife" converter*
- *Works inline with any digital press*
- *Works inline with GM Hotfoil/Screen embellishment units*
- *Upgrade to double varnish and turret*
- *Train an operator in one hour*
- *Online support and remote diagnostics*
- *Industry 4.0 ready*

SPECIFICATIONS	METRIC	IMPERIAL
Web width	50 - 330 mm	2 - 13"
Substrate thickness	50 - 200 µm	2 - 8 pt.
<b>Die Station</b>		
Semi-rotary speed	65 m/min	213 ft/min
Full-rotary speed	72 m/min	236 ft/min
Die plate size	50 - 558,8 mm	2 - 22"
<b>Unwinder</b>		
Diameter max.	700 mm	27.6"
Core diameter	76,2 or 152,4mm	3" or 6"
<b>Rewinder</b>		
Diameter max.	500 mm	19.7"
Standard core diameter	76,2 mm	3"
Waste matrix rewinder diameter	up to 800 mm on request	up to 31.5" on request
<b>Flexo Station</b>		
Print cylinder size	228 - 482,5 mm	9 - 19"
Spot varnish option with digital sensor register control and slow run		
<b>Slitting Station</b>		
Knife type	Pneumatic crush, smart crush, shear or razor	
Minimum distance crush	12,7 mm	0.5"
Minimum distance shear	10 mm	0.4"
Dimensions (WxDxH)	2,7 x 1,5 x 2,0 m	8.8 x 5.0 x 6.5 ft



**NEW**

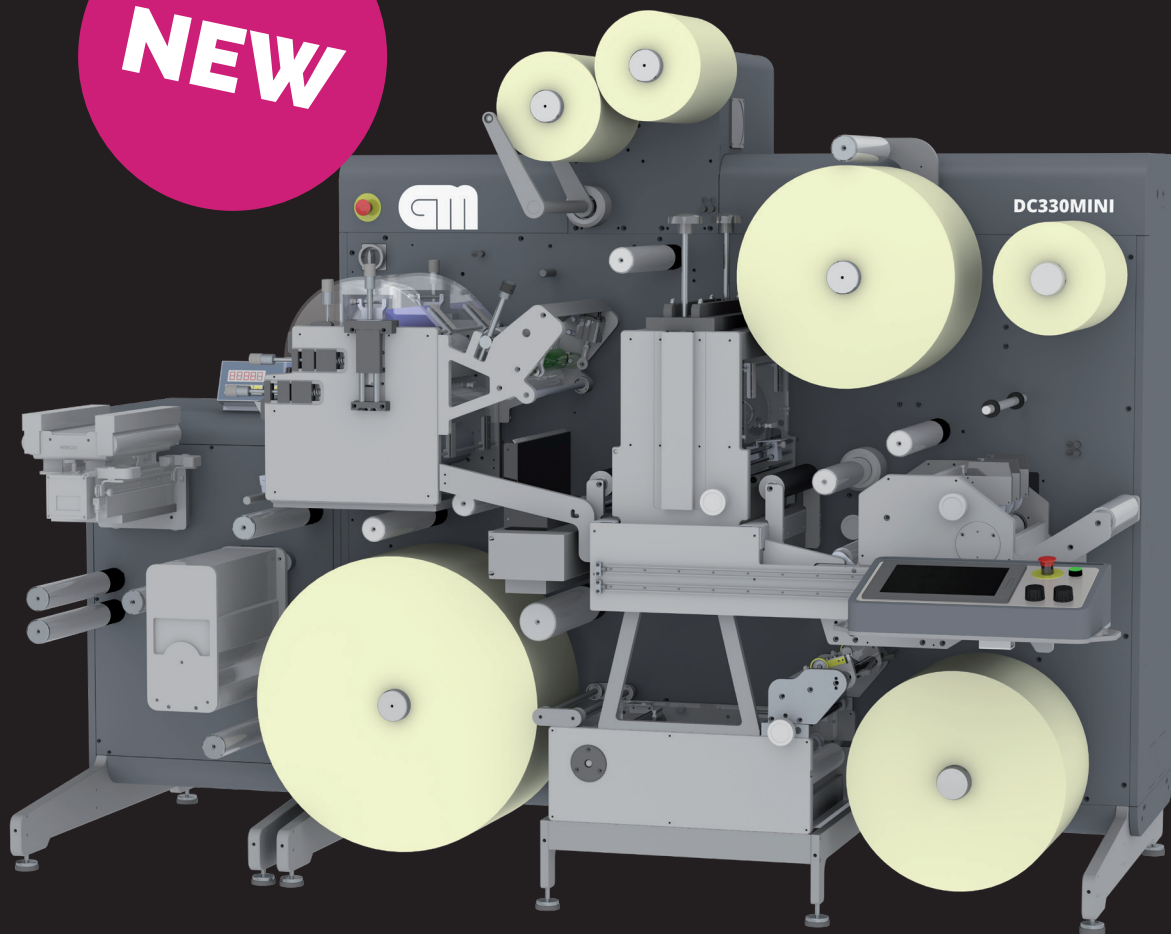

This latest generation of the digital label finishing machine has been redesigned and features new electronics, a newly-designed control panel and an updated user interface. Based on the DC330 platform designed and improved over 8 generations – the DC330MINI NEW has a strong and extremely proven background.

**All-in-one compact solution**

Like the previous generation, it maintains the same best small footprint to minimize waste and maximize productivity. **DC330MINI NEW** provides UV flexo varnish, lamination, super-gloss, cold-foil, die cutting and slit and rewind on one single compact platform.

The drive train in the DC330 series of machines is completely servo driven offering low maintenance servo-driven tension control and good registration. Minimum waste die dials in within one rotation. No station movement or mechanical setup needed and lastly graphical touch screen which shows the machine configuration, spindle directions and web-up.

**Online Support - easy web access and maintenance**

- Remote support and diagnostics using machine data
- Cloud statistics – operator login, productivity
- Insert a new module in hours, not days

**Smart converting machine**

- Industry leading user interface
- Precision cutting to reduce waste
- Best footprint and shortest web path
- Minimum waste
- Online Support
- High performance - up to 72m/min
- Inline options for any digital press
- TRESU close chamber varnish option for high speed applications
- Easy to use and learn

# DC330MINIflex

## Compact Full Feature Converting

- Adds full flexibility to the DC330MINI compact
- GM Automatic Slitting Station
- GM Semi-automatic turret rewinder
- Large graphical touch screen for easy operation
- Online support and remote diagnostics
- Industry 4.0 ready

SPECIFICATIONS	METRIC	IMPERIAL
Web width	50 - 330 mm	2 - 13"
Substrate thickness	50 - 200 µm	2 - 8 pt.
<b>Die Station</b>		
Semi-rotary speed	65 m/min	213 ft/min
Full-rotary speed	72 m/min	236 ft/min
Die plate size	50 - 558,8 mm	2 - 22"
<b>Unwinder</b>		
Diameter max.	700 mm	27.6"
Core diameter	76,2 or 152,4 mm	3" or 6"
<b>Rewinder</b>		
Diameter max.	500 mm	19.7"
Diameter max on Turret	400 mm	15.7"
Standard core diameter	76,2mm	3"
Waste matrix rewinder diameter	up to 800 mm on request	up to 31.5" on request
<b>Flexo Station</b>		
Print cylinder size	228 - 482,5 mm	9 - 19"
Spot varnish option with digital sensor register control and slow run		
<b>Slitting Station</b>		
Knife type	Pneumatic crush, smart crush, shear, razor or AutoSlitting	
Minimum distance crush/razor	12,7 mm	0.5"
Minimum distance shear (manual setup)	10 mm	0.4"
Minimum distance shear (automatic setup)	20 mm	0.8"
Dimensions with turret (WxDxH)	3,7 x 1,5 x 2,0 m	12.2 x 5.0 x 6.5 ft

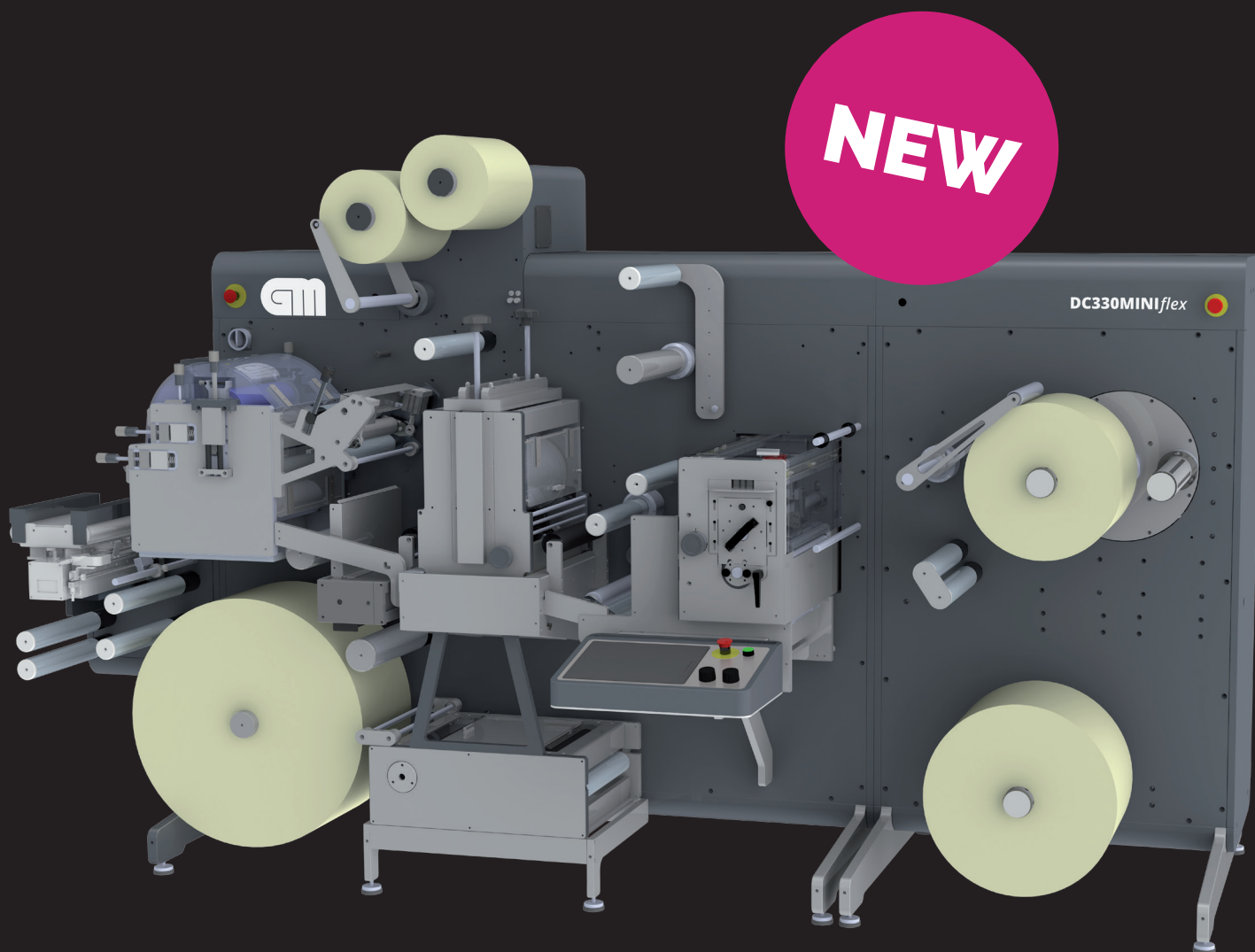

The compact full feature choice. Powerful yet economic finishing line with the smart essential options like GM Automatic Slitting Station and semi-automatic turret rewriter.

The **MINIflex** is prepared for in-line operation with all major digital presses. The machine adds full flexibility to the market-leading compact finisher DC330MINI.

The **DC330MINIflex** has all you need to convert labels. Varnish, semi-rotary die cut, slit, and dual rewind. Optional spot varnish, cold foil, lamination, inline buffer, corona, web clean, back scoring, razor slitting and more. When used together with a digital label press, this innovative unit gives professional label printers a complete and versatile solution for high volume digital printing.

- Modern platform ensuring quick setup the die-cutting station in register and high stability level
- Industry leading user interface giving the operator a graphical representation of the machine as installed
- GM Automatic Slitting Station option
- GM Web advance for fast roll change option
- GM Semi-automatic turret option fully controlled from an integrated main control panel
- High performance – semi-rotary up to 65m/min, full-rotary up to 72m/min
- Fully customizable for individual needs
- Inline options for any digital press
- Online Support – easy web access and maintenance

# DC330NANO

## Ultra Compact Converting

- All you need to start label production
- Ideal for entry-level digital label printers
- High value for money
- Lamination included
- Fast finishing 50 m/min
- Online support and remote diagnostics
- Industry 4.0 ready

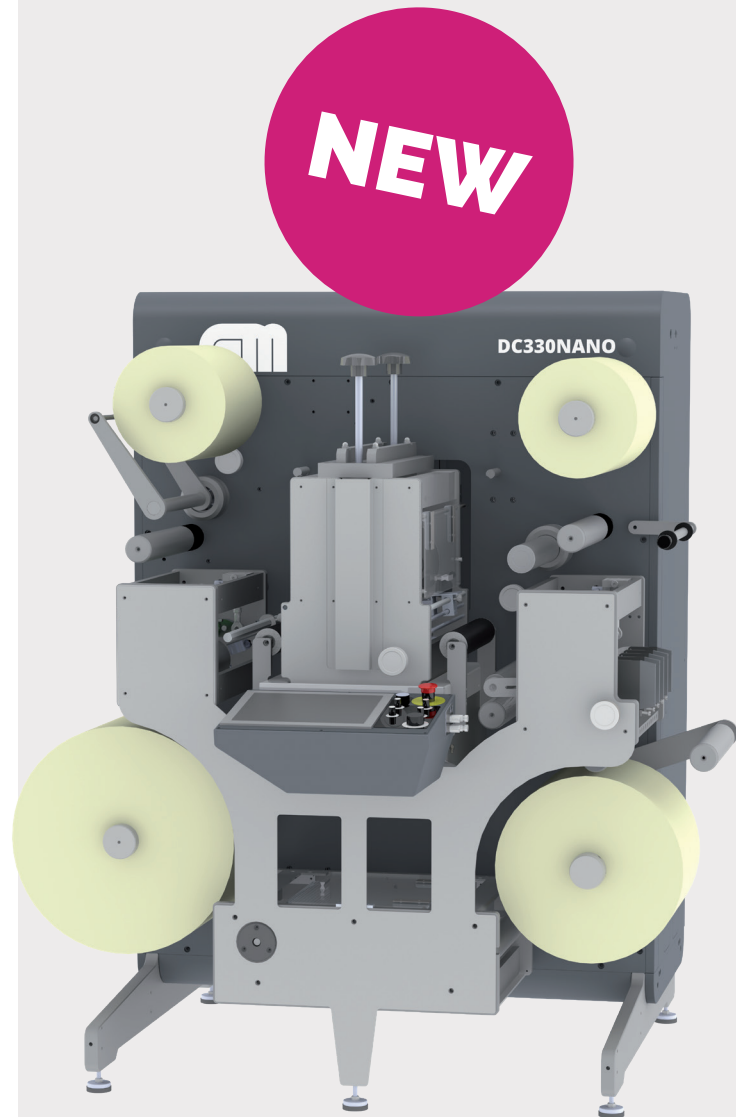

SPECIFICATIONS	METRIC	IMPERIAL
Web width	50 - 330 mm	2 - 13"
Substrate thickness	50 - 200 µm	2 - 8 pt.
<b>Die Station</b>		
Semi-rotary speed	32 (50*) m/min	105 (164*) ft/min
Full-rotary speed	72 m/min	236 ft/min
Die plate size	50 - 558,8 mm	2 - 22"
<b>Unwinder</b>		
Diameter max.	500 mm	19.7"
Core diameter	76.2 or 152.4mm	3 or 6"
<b>Rewinder - standard single shaft</b>		
Diameter max.	400 mm	15.7"
Standard core diameter	76,2 mm	3"
<b>Slitting Station</b>		
Knife type	Pneumatic crush, smart crush	
Minimum distance crush	12,7 mm	0.5"
Minimum distance shear		
Dimensions (WxDxH)	1,8m x 1,4m x 1,6m	

\* with Productivity Pack

Ultra compact, cost-effective unit for lamination, die-cutting, and slitting. As digital label printing continues to grow, label-printing houses are realizing the need for all-inclusive digital printing systems that provide value-adding features for producing fully finished labels. The **DC330NANO** offers the ideal solution. The **DC330NANO** offers unwinding, self-adhesive lamination, semi-rotary die cutting and length slitting on a compact 1.3x1.4m platform. The unit is ideal as a converter for a small digital press or as a backup to an existing finishing line. The unit can run either offline or inline.

The **DC330NANO** is prepared for integration with market standard Memjet modules. This turns this small unit into a hybrid digital press.

# DC Options



## GM SmartView

Ideal automated Industry 4.0 system. It provides real time data of all GM converting lines owned by the customer. GM SmartView ensures integration with MIS and compliance with JDF standard.

It can be used to get a quick overview of all machines running, to show the job ID and operator name, current state of the machine etc.

It's meant to be used in a supervisor office, so that the supervisor can get a quick overview of the current production status of the machines. lastly graphical touch screen which shows the machine configuration, spindle directions and web-up.

The livestream shows:

- Operator Name,
- Job ID
- Current machine status (Run, Idle, Error)
- Current web speed
- Current distance run

SPECIFICATIONS	METRIC	IMPERIAL
Web width	330, 350 and 550 mm	13.8, 19.7 and 21.6"
Substrate thickness	50 - 200 µm	2 - 8 pt.
Knife type	Rotary shear / optional razor blades	
Minimum distance between the knives	20 mm	0.8"
Minimum side trim	1 mm	0.04"
Number of knives	3 (default) / 16 max.	
Setup	Barcode, Key in, Manual	
Setup time	6 seconds / knife	

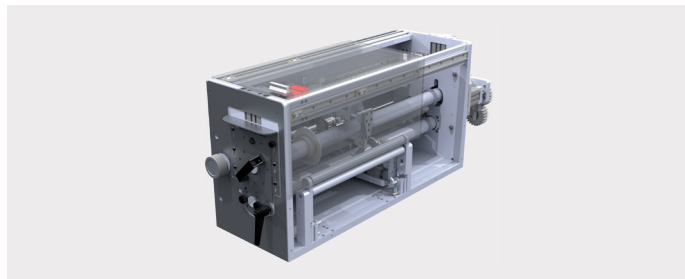

## GM SmartSlit

With the new automatic knife box from GM, you can set your slitting knives in three different ways: Fill in the table on the touchscreen with the size of your labels, scan the generated barcode or simply reload an existing job from the hard drive. Then simply press "Place" on the touchscreen and the automatic knife box will set the knives according to your request in a matter of seconds. Setting 16 knives in 2 minutes.

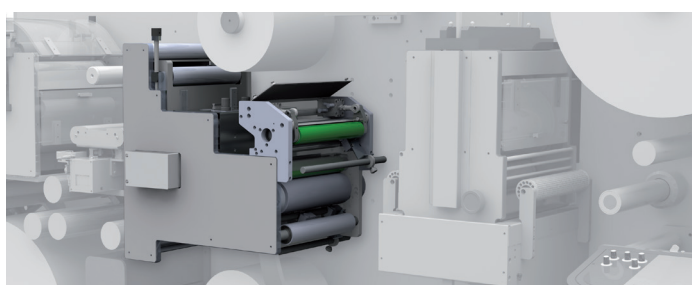

## GM SmartLam

Multi-layer labels are often used for pharmaceutical and medical label applications – especially when government regulations require

product information to remain intact with the product. With a multi-layer label, you can also add recipes on food labels, promote sweepstakes / giveaways, detailed instructions, give multilingual information, launch a new product, attract buyers with coupons and display legal text.

SPECIFICATIONS	METRIC	IMPERIAL
Web width	330, 350 and 550 mm	13.8, 19.7 and 21.6"
Speed	up to 72 m/min	236 ft/min
Substrate thickness	30 - 60 µm	1.2 - 2.4 pt.
Verified Substrates	PP on Silicone Liner	
Repeat length	50 - 304 mm	2 - 12"

## GM SmartLoad

An automatic flexible die plate changing system to reduce changeover times and to ensure an accurate die mounting in seconds – every time.

SPECIFICATIONS	METRIC	IMPERIAL
Die plate size	50,8 - 558,8 mm	2 - 22"
Web width	50 - 350 mm	2 - 14"
Changing time	10 sec	

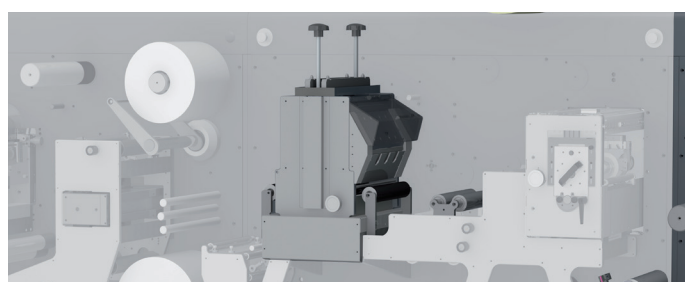

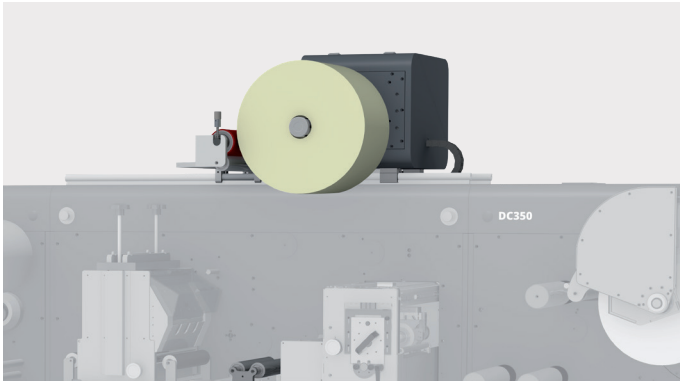

## GM SmartStrip

A remarkable waste matrix stripping and rewinding system with servo controlled tension. The waste matrix is peeled off around an idle rubber roller and immediately transferred to the rewinder. It ensures trouble-free operation even while converting delicate substrates and complex label shapes at high speed.

SPECIFICATIONS	METRIC	IMPERIAL
Web width	330, 350 and 550 mm	13.8, 19.7 and 21.6"
Speed	up to 72 m/min	236 ft/min

## GM SmartTurret

NEW fully servo controlled automatic turret rewinder. Provides efficient production without stopping when changing rolls. This unique solution allows you smooth varnishing of the labels with no traces of the wet roller onto the web.

SPECIFICATIONS	METRIC	IMPERIAL
Web width	350 mm	19.7"
Rewind	2 position turret	
Diameter max on Turret	450 mm	17.5"
Diameter max on bottom shaft	700 mm	27.5"
Standard core diameter	76,2 mm	3"

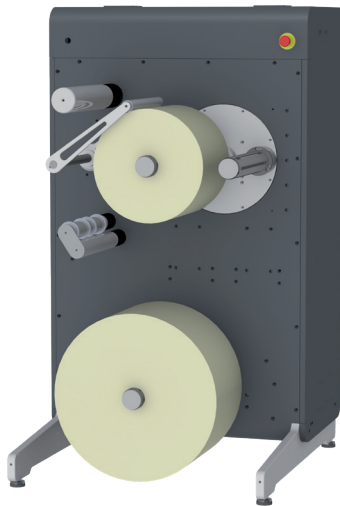
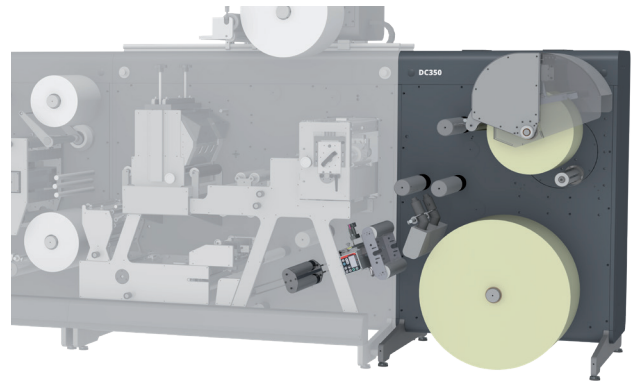

## GM Semi Automatic Turret

GM offers a range of semi-automatic turret rewinds for wide range GM finishers. The GM Turret offers very quick make ready times unlike conventional rewinding. This allows shorter runs to be produced both quickly and more efficiently.

SPECIFICATIONS	METRIC	IMPERIAL
Web width	330, 350 and 550 mm	13.8, 19.7 and 21.6"
Rewind	2 position turret	
Diameter max on Turret	400 mm	15.7"
Diameter max on bottom shaft	500 mm	19.7"
Standard core diameter	76,2 mm	3"

## GM SmartCrush

An ultra-quick set knives system, allowing fast and precise setting of each crush knife – also while running.

SPECIFICATIONS	METRIC	IMPERIAL
Web width	330, 350, 550 mm	13.8, 19.7, 21.6"
Minimum distance crush	30 mm	1.2"
Knife type	Pneumatic SmartCrush	

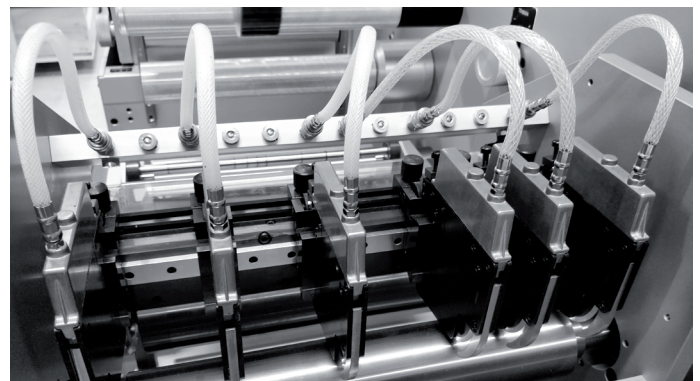

## GM SmartChill - New Chilling Solution

The SmartChill eliminates curling and melting issues when UV curing thin foil substrates. Installing the SmartChill maximises the variety of substrates applicable. And it is retro-fittable!

SPECIFICATIONS	METRIC	IMPERIAL
Web width	330, 350 and 550 mm	13.8, 19.7 and 21.6"
Rewind	2 position turret	
Diameter max on Turret	400 mm	15.7"
Diameter max on bottom shaft	500 mm	19.7"
Standard core diameter	76,2 mm	3"

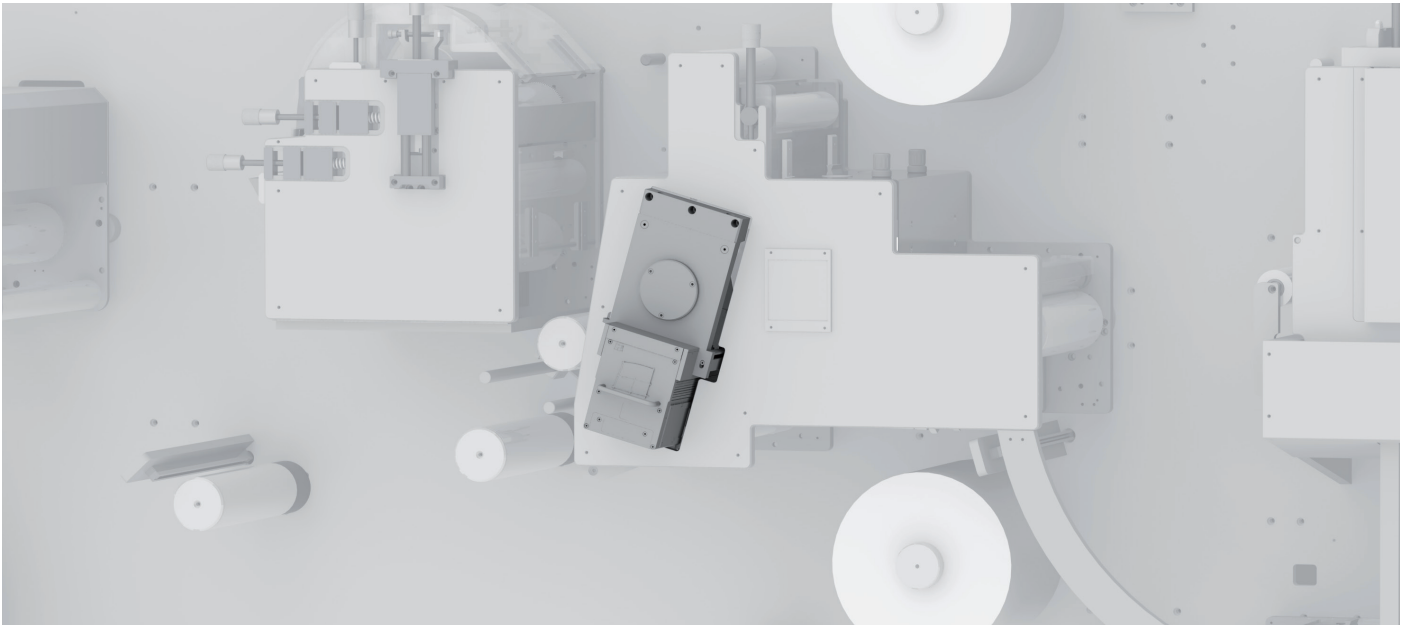

## GM Buffers

The best of both worlds!

- Easy switch between inline and offline mode
- Synchronizes the speed between digital press and finisher
- Allows operator time to change the roll
- Stores 52 meters and allows up to 4 minutes continuous production

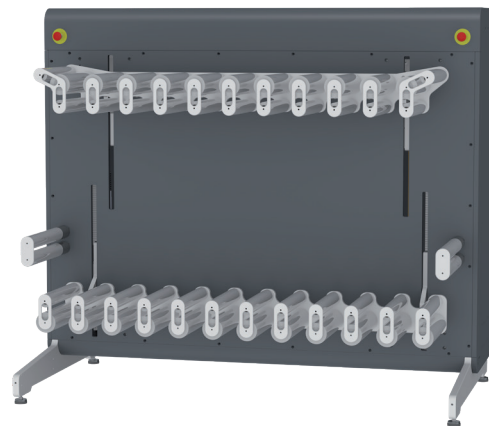

LA

SEE

R





# LC330 & DC330Hybrid

## Compact Laser & Hybrid Finishing

- Fully digital mirror system for superior laser cut quality
- High-performance LUXINAR sealed lasers
- Precise register and cut depth control
- Excellent choice for digital label press
- Zero changeover time
- Job change on the fly
- No die plate cost
- Online support and remote diagnostics
- Industry 4.0 ready

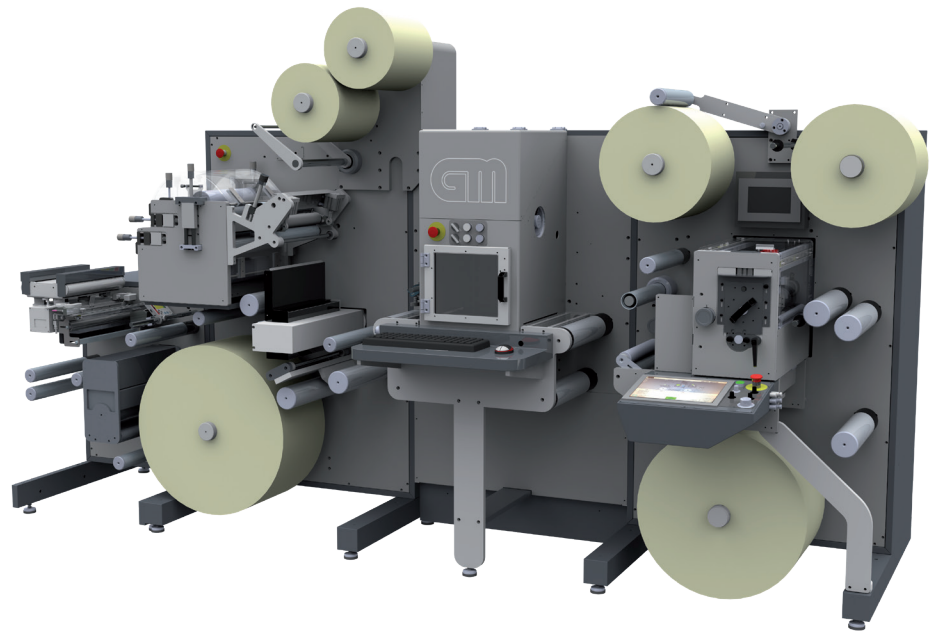

### SPECIFICATIONS

	METRIC	IMPERIAL
Web width	50 - 300 mm	2-13"
Substrate thickness	20 - 200 µm	0.8 - 8 pt.
<b>Die Station</b>		
Semi-rotary speed	50 m/min	164 ft/min
Full-rotary speed	72 m/min	236 ft/min
Die plate size (with standard 25" cylinder)	50 - 558,8 mm	2 - 22"
<b>Laser Die</b>		
Power	150, 250 or 350W	
Laser type	Sealed, single head pulsed CO2	
<b>Unwinder</b>		
Diameter max.	700 mm	27.5"
Core diameter	76,2 mm or 152,4 mm	3 or 6"

The **LC330** is a compact, economic and fully digital laser finishing machine. Simply download the file from the pre-press department and the laser module is ready. The system can be fitted with an optional barcode reader for faster re-load of existing jobs. The laser power ranges from 150-350W (400-1000W peak). It is possible to cut with different power levels on the same label. The standard LC330 has laser die, slitting and dual rewind. The unit is prepared for flexo varnish, spot varnish, lamination, cold foil and automatic knife box.

The standard **DC330HYBRID** configuration is an unique combination of both conventional and digital cutting systems and gives the benefits of both worlds. Fast delivery with the laser and high speed operation for long runs on the conventional cutting system.



SPECIFICATIONS	METRIC	IMPERIAL
<b>Rewinder</b>		
Diameter max.	500 mm	19.5"
Core diameter	25 - 152 mm	1 - 6"
<b>Flexo Station</b>		
Varnishing roller	228,6 - 482,6 mm	9 - 19"
Spot varnish option with registration and slow run		
<b>Slitting Station</b>		
Knife type	Pneumatic crush, shear, razor or AutoSlitting	
Minimum distance crush	12,7 mm	0.5"
Minimum distance shear	10 mm	0.4"
Minimum distance shear (automatic setup)	20 mm	0.8"
Dimensions LC330	3,6 x 2,3 x 2,1 m	11.9 x 7.6 x 6.9 ft
Dimensions DC330Hybrid	4.9 x 2.3 x 1.6 m	15.9 x 7.6 x 5.4 ft





# 330FB

## Premium Wine Label Line

- NEW 50-ton Hot Foil unit
- NEW fast Screen Print unit
- NEW advanced multi-step Foil Saver
- High precision movable UV screen system
- SmartRegister foil for holograms
- Runs inline with all GM die-cutters



SPECIFICATIONS	METRIC	IMPERIAL
Web width	50 - 330 mm	2 - 13"
Substrate thickness	50 - 200 µm	2 - 8 pt.
<b>Hot Foil &amp; Embossing</b>		
Max Speed*	44 m/min	143 ft/min
Hotstamp plate size (WxL)	330 x 304,8 mm	13 x 12"
<b>Screen Printing</b>		
Max Speed*	20 m/min	65 ft/min
Print area	330 x 330 mm	13 x 13"
Max repeat	1m	39.4"
Frame full size (WxDxH)	660 x 500 x 30 mm	26 x 19.7 x 1.2"
<b>Unwinder</b>		
Max. unwind diameter	700 mm	27.6"
Core diameter (min-max or a,b,c)	76,2 or 152,4 mm	3 or 6"
<b>Rewinder</b>		
Max. rewind diameter	700 mm	27.6"
Core diameter (min-max or a,b,c)	25 - 152,4 mm	1 - 6"
Dimensions (WxDxH)	5,0 x 1,4 x 1,9 m	16.4 x 4.6 x 6.3 ft

\*Based on 304.8mm repeat \*\*Based on 304.8mm repeat, 250mm image

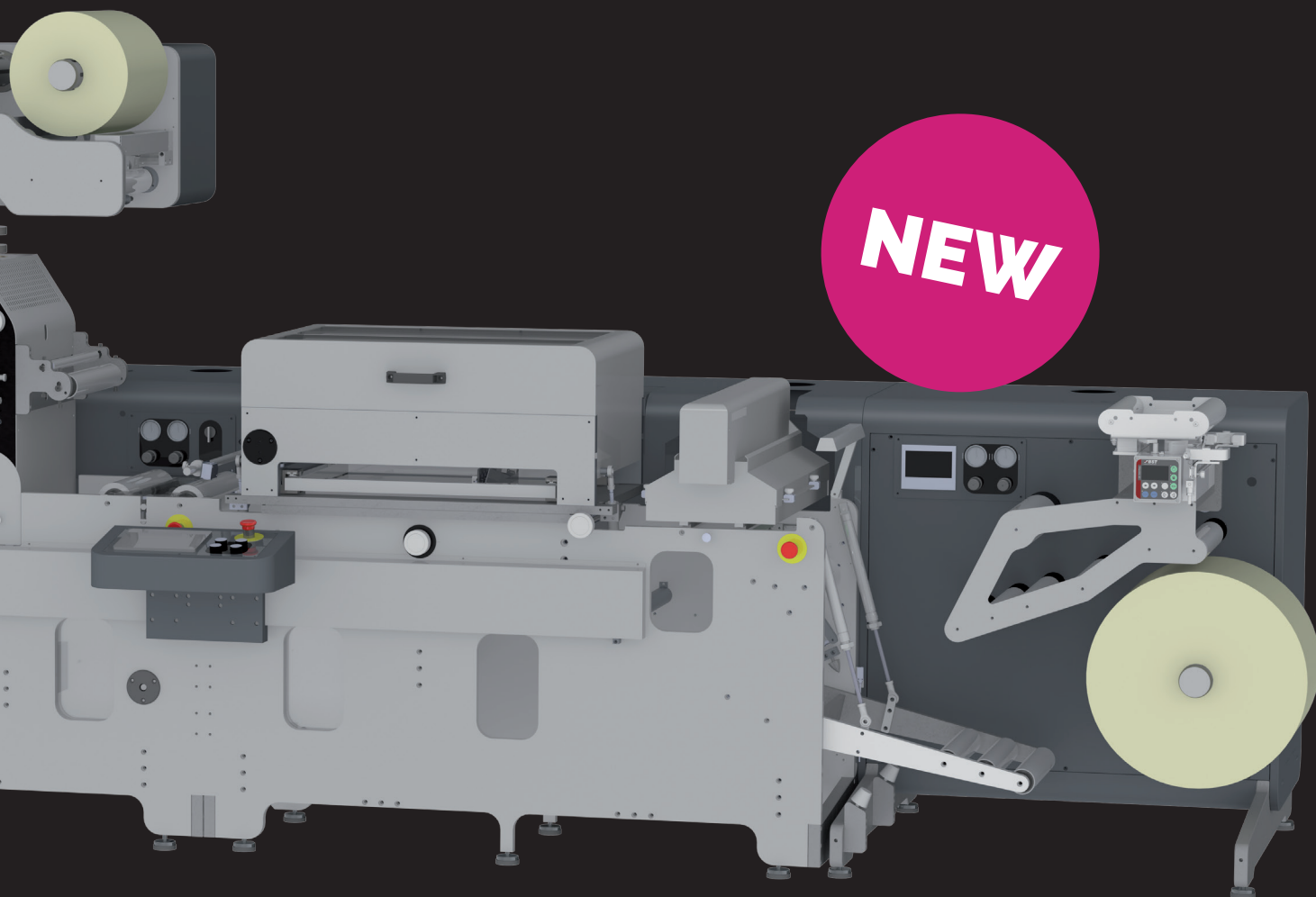

High value labels grow with the lucrative market of embellishments. The **330FB** is a precision, 50-ton pressure heavy duty, stamping unit for production of high quality labels. The machine can do foil stamping, embossing or one pass foil and embossing.

The best way to impress consumers is the right combination of quality and beauty, and this is where the **330FB** flatbed hot stamp unit from Grafisk Maskinfabrik will help you out. The **330FB** is an innovative unit that will give your labels an impressive and unique look-and-feel. On the matter of the quality of hot stamping, the flatbed is the best choice, and on the matter of beauty, the FB330 can add intricate details of gold, silver or even holograms to your labels.

Moreover, the **330FB** will do both hot foil and cold embossing to serve all your needs. Advanced features such as foil saver, servo-register and electronic temperature control & BST web-guide come as standard.

#### New hi-tech features

- NEW fast and heavy-weight Hot Foil unit applying up to 50-ton
- NEW fast Screen Print unit
- NEW advanced multi-step Foil Saver option
- NEW registering foil for holograms option
- Sophisticated high precision movable UV screen system – make as big thickness of varnish as you need
- Servomotors on unwinder and rewinder for excellent web tension control
- The second webguide added at rewinder to improve stability of the web and to provide excellent registration
- Runs inline with DD330MINI converter
- New electronic platform, ensuring better machine operation and online support

# HOTFB330

## Standalone Hot Foil

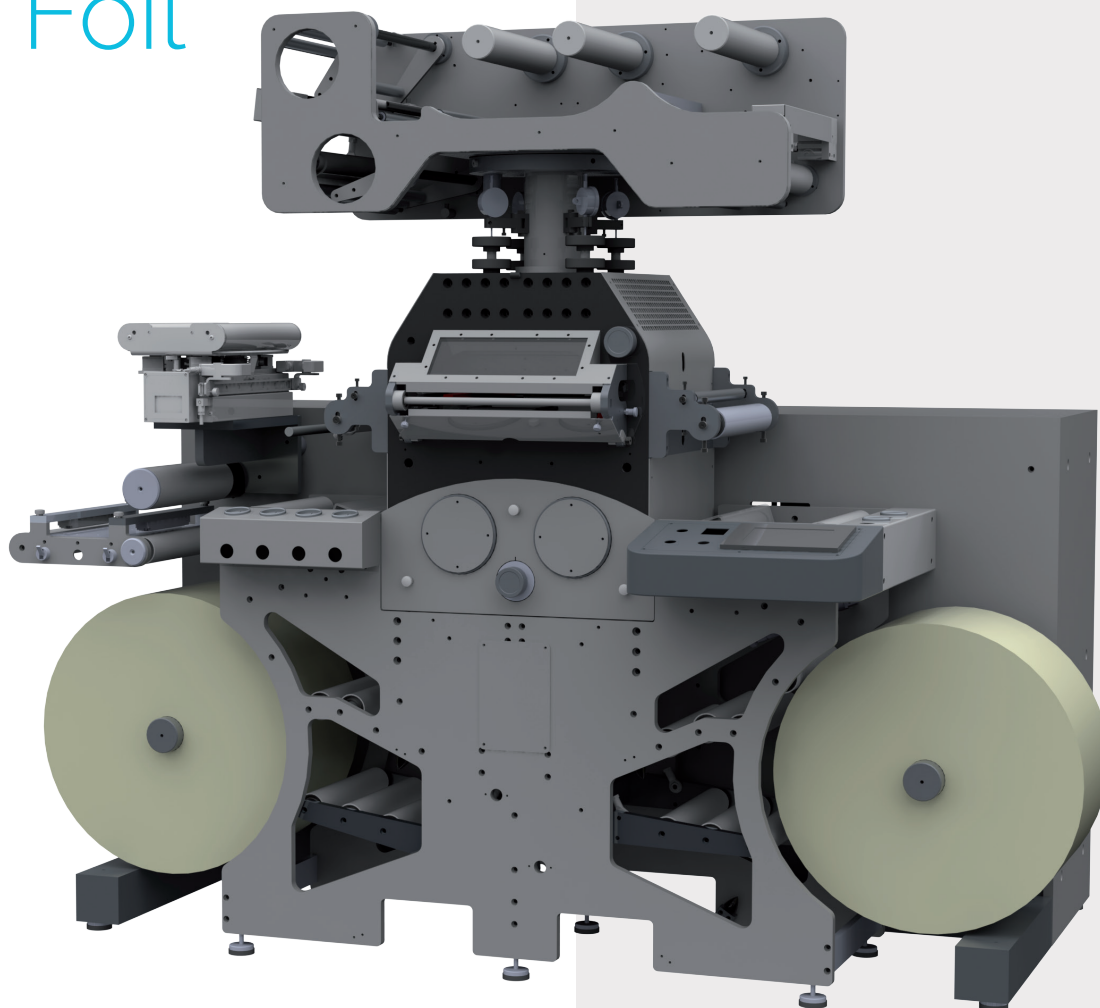

Hot stamping and embossing add the final touch to labels. Gold or silver effects combined with embossing give great embellishment results.

The GM type **HOTFB330** is a 50-ton precision stamping machine for production of high quality labels. The machine can be used for foil stamping, embossing or one pass foil & embossing.

- Servo register system for printed marks or optional label gap sensor
- BST ultrasonic web guide.
- Easy loading of plate and counter plate in the hot state
- Graphical touch screen with label counter, meter counter, alarms & more
- Easy web access and maintenance
- Runs offline or inline with other GM converting machines
- Modern single sided frame for easy threading and maintenance

SPECIFICATIONS	METRIC	IMPERIAL
Web width	100 - 330 mm	2.5 - 13"
Substrate thickness	20 - 200 µm	0.8 - 8 pt.
<b>Hot Foil &amp; Embossing</b>		
Speed	Up to 20 m/min	Up to 65 ft/min
Stamp plate size	304,8 x 330 mm	12 x 13"
Total thickness of the plate	5 - 15 mm	0.2 - 0.6"
<b>Unwinder</b>		
Diameter max.	600 mm	19.7"
Core diameter	76,2 or 152,4 mm	3 or 6"
<b>Rewinder</b>		
Diameter max.	500 mm	19.7"
Core diameter	76,2 or 152,4 mm	3 or 6"
Dimensions (WxDxH)	2,2 x 1,3 x 1,9 m	7.3 x 4.1 x 6.2 ft



# SC330 Precision Screen Printer

- High speed Screen Print unit
- Sophisticated high precision movable UV screen system
- Broad UV area for high build varnish

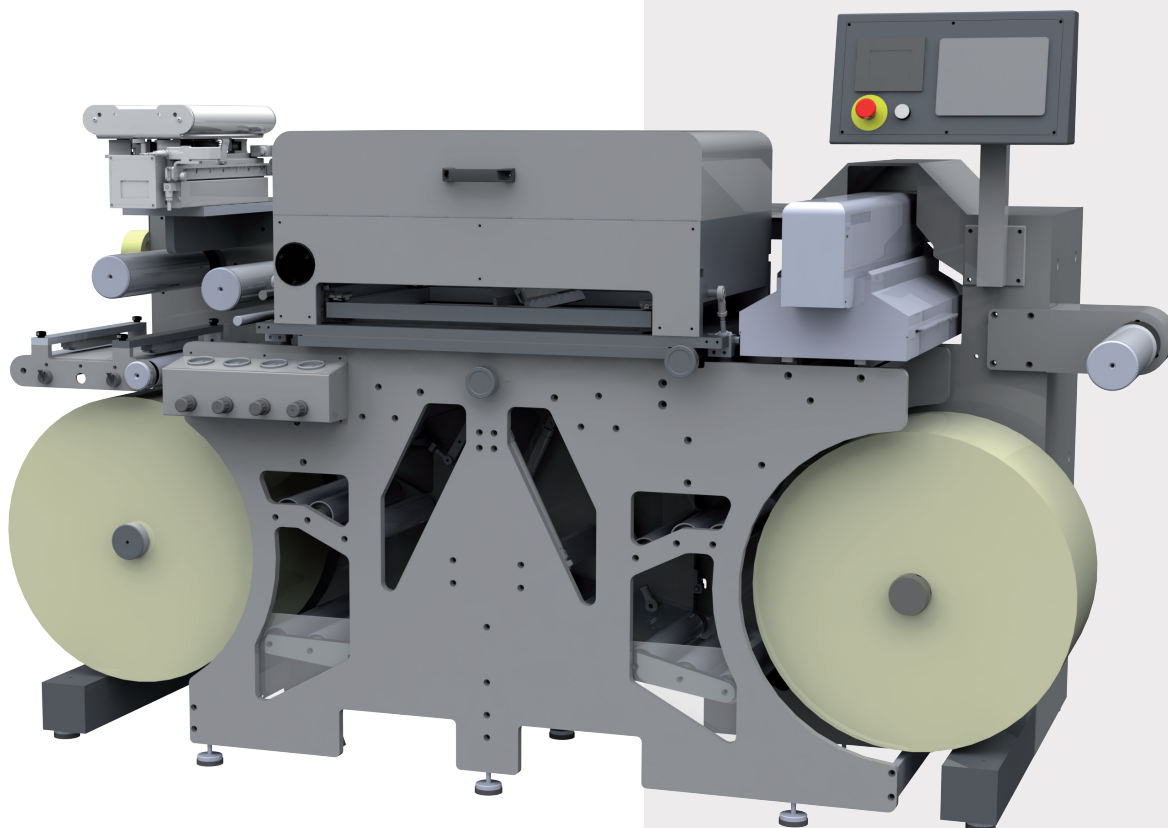

SPECIFICATIONS	METRIC	IMPERIAL
Web width	50 - 330 mm	2 - 13"
Substrate thickness	50 - 200 µm	0.8 - 8 pt.
<b>Screen Printing</b>		
Machine speed	5 - 15 m/min	16 - 49 ft/min
Print speed	4000 imp/h	
Screen print area	330 x 330 mm	13 x 13"
Frame full size (WxDxH)	660 x 500 x 30 mm	26 x 19.7 x 1.2"
<b>Unwinder</b>		
Diameter max.	600 mm	23.6"
Core diameter	76,2 or 152,4	3 or 6"
<b>Rewinder</b>		
Diameter max.	500 mm	19.7"
Core diameter	25 - 152mm	1 - 6"
Dimensions (WxDxH)	2,3 x 1,2 x 1,5 m	7.6 x 3.9 x 4.9 ft

Screen printing is becoming more and more important in today's labels. Examples are warning triangles and high value wine labels.

The **SC330** has a servo system that ensures perfect register on tight jobs. The frame size is 660x500mm. Frames can be made locally at a low cost. A special "after glow" feature cures even high layers of ink.

The **SC330** is compatible with tooling from existing equipment. Setting up the **SC330** is very simple and fast, which makes it suitable to complete very short runs. Apart from being a cost-efficient alternative to rotary printing due to the low costs of mesh and frame, flat bed screen printing is also a good match for digital print - as the screen can be very fast for day to day production of see **330FB** on the previous page for specifications.

INSPIRE  
ION &  
SLITTT  
REWWI  
DERS

ECT

ER

N

# SR350 Slitter Rewinder with Inspection

- Up to 300m/min
- The shortest start/stop distance on the market
- 100% inspection
- Seated operator work position
- Semi Automatic Turret

SPECIFICATIONS	METRIC	IMPERIAL
Web width	50 - 350 mm	2 - 13.8"
Substrate thickness	50 - 200 µm	2 - 7.9 pt.
Max speed	300 m/min	984 ft/min
Max speed with Camera Inspection	200 m/min	656 ft/min
<b>Unwinder</b>		
Diameter max	700 mm	27.6"
Core diameter	76 mm	3"
<b>Rewinder - Single, Dual or Turret option</b>		
Diameter max	500 mm	19.7"
Diameter max on Turret	400 mm	15.7"
Core diameter	25 - 152 mm	1 - 6"
<b>Slitting Station</b>		
Knife type	Pneumatic crush, shear, razor or AutoSlitting	
Minimum distance crush / razor	12,7 mm	0.5"
Minimum distance shear	10 mm	0.4"
Minimum distance autoknife	20 mm	0.8"
Camera Inspection System	Nikka M+ or other	
Webguide	BST Ultrasonic	
Dimensions (WxDxH)	1,9 x 1,5 x 1,2 m	6.5 x 4.9 x 4.0 ft.
Dimensions with turret (WxDxH)	3,0 x 1,2 x 1,2 m	9.8 x 4.9 x 4.0 ft.



**SR350** is a highly reliable, high-speed slitter inspection rewind machine. The SR350 features the newest in servo motion technology and a unique option for auto-set knives. Designed for a wide range of SA labels on paper and plastic liners including the UPM PP30 and AD PET 23µm liners, booklet, tube laminate, Alufoil, Tyvek, cardboard, multilaminate.

Quick set-up routines with the build in job-recall system ensure all systems are ready to run simultaneously, making it faster to change jobs. Fully modular open concept allows to add the options such as 100% inspection camera, scanner bar code reader, ink-jet systems, register die-cutters, automatic slitting unit, waste vacuum ejector and turret rewinder.

- High speed up to 300m/min for efficient converting
- Code for laser & slitting – possibility to combine two machines working together thanks to using the same barcodes. The knives are set automatically utilizing an information from barcodes.
- Advanced Nikka M1 label inspection system option, machine stops precisely within 10cm if detects any error
- Full rotary Die Cut option for white labels
- Domino inkjet printing option for codes producing
- Upgrade possible – more options available
- Easy web access and maintenance
- Web advance for fast roll change

# IR330

## Inspection Rewinder

- Turn key pharma full inspection solution
- Bi-directional drive for inspection, rewind and re-inspection
- Multilayer label insertion
- Inkjet numbering

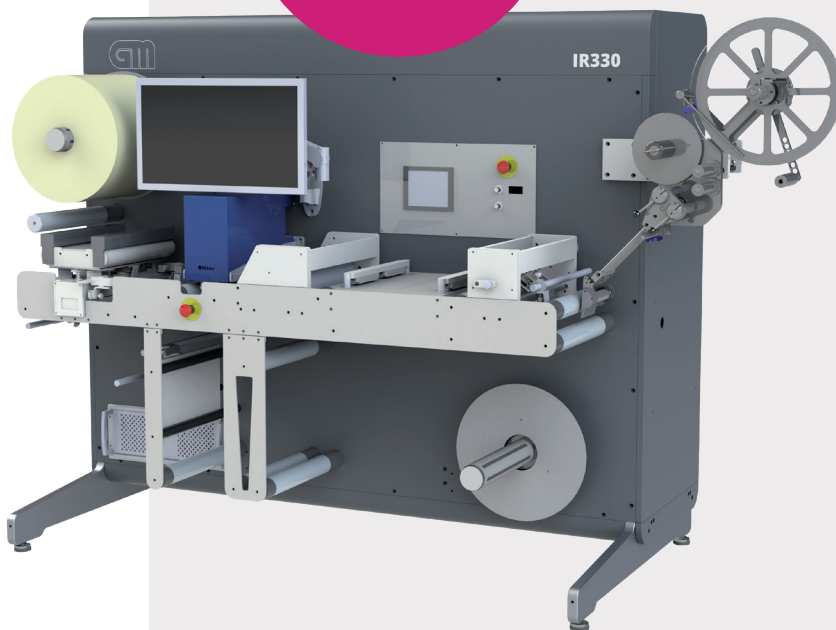

The **IR330** is fully compliant with all pharmaceutical and security inspection demands. It has been designed in accordance with the new line and built on a new modern electronic platform. The machine is fully configurable and retrofittable. It is distinguished by high speed and high precision.

Thanks to short inspection table the machine has a small footprint and saves the space. It stops precisely and accurately for label inspection after detecting any errors.

The system is bi-directional, which allows the users to back-up and re-check a defective label making sure the job is 100% perfect. The inspection camera system stops the machine when a fault has been detected and moves the faulty label back to the repair table.

The machine has an easy to use touchscreen and features step-less electronic tension on both unwind and rewind spindles. A web guide with ultrasonic sensor is fitted as standard. The web guide has a build-in splice table with two air-controlled clamps. There are many possible options to the machine: razor blade system, multi-layer label insertion or inkjet head - the printing system can print a report for each roll of labels, according to end-user requirements.

The rewinder is equipped with air expansion mandrels with sleeves, easily exchangeable to other sizes. The rewinder can be set at rewinding label-in or label-out.

SPECIFICATIONS	METRIC	IMPERIAL
Web width	330	13,78"
Substrate thickness	50 - 200 µm	2 - 7.9 pt.
Max speed	100 m/min	328 ft/min
Max unwind diameter	400 mm	15.7"
Pneumatic shaft diameter	25mm-76 mm	1 - 3"
Max rewind diameter	400 mm	15.7"
Pneumatic shaft diameter	25 - 76 mm	1 - 3"
Camera Inspection System	Nikka M+	
	Alternative AVT, Tube Scan, BST available	
Webguide	BST Ultrasonic	
Slitting Station	Razor knife	
Label Dispenser (optional)	30 m/min	98 ft/min
Dimensions (WxDxH)	2,6 x 1,1 x 1,7 m	8.5 x 3.6 x 5.6 ft.

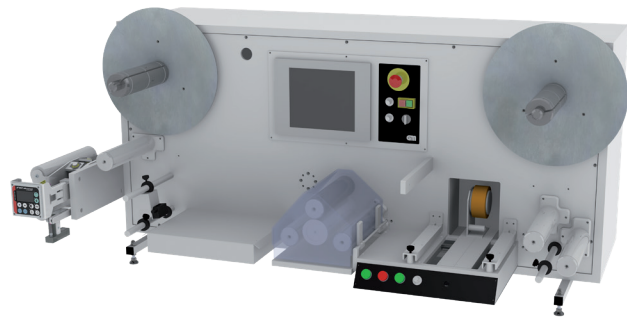

## LRN25T - Inspection Rewinder with Inkjet Support

The **LRN25T** rewinding and inspection unit is designed especially for demanding rewind jobs of high quality. The two-way revider has web tension control, nip and adjustable splice table with pneumatic splice clamps. It is equipped with air expansion mandrels with sleeves easily exchangeable to other sizes and can be fitted with an

SPECIFICATIONS	METRIC	IMPERIAL
Max web width	250 mm	9.8"
Speed	200 m/min	328 - 984 ft/min
Max unwind diameter	400 mm	15.7"
Max rewind diameter	400 mm	15.7"
	subject to web width and material	
Pneumatic shaft diameter	25 - 120mm	1 - 4.7"
Dimensions (WxDxH)	1,8 x 0,9 x 0,9 m	6.0 x 3.1 x 2.8 ft

inkjet system. This turns the revider into an excellent machine for making labels, tickets, tags, forms, barcodes, cards in one process. Quicker, easier setup compared to other variable data printers. It ensures trouble-free operation even while converting delicate substrates and complex label shapes at high speed.



## LRFT25 - Inspection Rewinder

The **LRFT-25** rewinders are vertical table top models with splicing table and two motor controllers - one working as an unwinder and the other as a revider and the design offers control of the web tension which ensures superior winding quality. The mandrels are air expansion mandrels with sleeves easily exchangeable to other sizes. A touch panel makes the operation of the machine very easy

SPECIFICATIONS	METRIC	IMPERIAL
Max web width	250 mm	9.8"
Speed	100 - 300 m/min	328 - 984 ft/min
	depending on diameter	
Max unwind diameter	400 mm	15.7"
Max rewind diameter	400 mm	15.7"
Pneumatic shaft diameter	25 - 120 mm	1 - 4.7"
Dimensions (WxDxH)	1,3 x 0,8 x 0,8 m	4.3 x 2.6 x 2.6 ft.

with graphic figures showing the rewind direction, and the direction of rotation for the shafts. The machine has integrated label counter. Options include web guide, missing label system and meter counter. In case of a missing label, the machine stops and places the error on the splice table with high precision. A small LR11T "at table" version is also available for narrow webs.

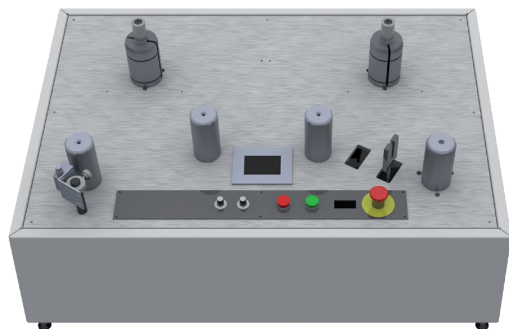

## LR11T - Inspection Rewinder

The **LR11T** is a two-way tabletop revider with web tension control for fast rewinding of labels. The machine is available as a simple revider with no inspection and as an inspection revider with

SPECIFICATIONS	METRIC	IMPERIAL
Max web width	110 mm	4.3"
Speed	250 - 350 m/min	820 - 1148 ft/min
Max unwind diameter	300 - 500 mm	11.8 - 19.7"
Max rewind diameter	300 - 400 mm	11.8 - 15.7"
Pneumatic shaft diameter	25 - 120 mm	1 - 4.7"
Dimensions (WxDxH)	1,1 x 0,7 x 0,4 m	3.6 x 2.3 x 1.3 ft.

missing label and missing matrix detection. The inspection option is adapted to both opaque and transparent labels on a transparent liner.

WILLIAM

WILLIAM

WILLIAM

WILLIAM

WILLIAM

# HL500

## Hot Laminator

Fully Integrated Hot Laminator for photo books & book covers

**HL500** is a high performance compact hot lamination system dedicated to the refining process in the production of high-quality photo books, book covers and photo prints. The machine can be fully integrated with most digital presses providing efficient online production. Depending on the configuration, the **HL500** operates in various modes: roll to roll, roll to sheet and optionally - in length slitting mode. The unique design of the device means that in addition to hot foiling, it can also be used for UV varnishing, spot varnishing with registration and cold UV lamination.

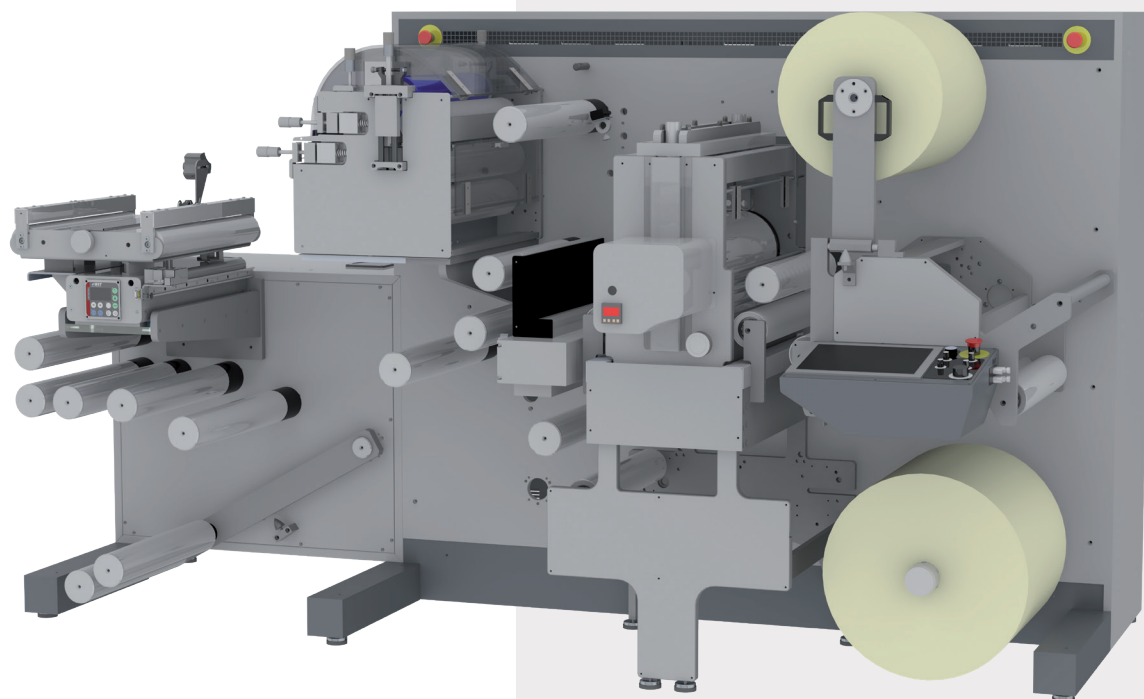

SPECIFICATIONS	METRIC	IMPERIAL
Web width	200 - 502 mm	8 - 19.8"
Substrate thickness	80 - 350 gsm	
Max speed	20 m/min	66 ft/min
<b>Rewinder</b>		
Max. Internal rewind	Ø450mm	17.7"
Core diameter	76.2 or 152.4mm	3 or 6"
<b>Hot Lam Cylinder</b>		
Lam cyl circumference	635 mm	25"
Lam cyl diameter	202,23 mm	8"
Lam cyl area	32104 mm <sup>2</sup>	50 in <sup>2</sup>
Width	523 mm	20.6 in
<b>Flexo Station</b>		
Print cylinder size	228 - 482,5 mm	9 - 19"
<b>Slitting Station</b>		
	Optional	
Knife type	Pneumatic crush, shear or razor knife	
Minimum distance crush/razor	12,7 mm	0.5"
Minimum distance shear	10 mm	0.4"
Size (WxDxH)	2,9 x 1,5 x 1,7 m	9.5 x 4.9 x 5.6 ft.

Thanks to hard chrome-plated heating cylinder combined with lamination film your clients get extremely high gloss of the laminate, which ensures excellent photographic results. Hard chrome used as coating on the cylinder guarantees good heat conductivity as well as the high surface tension, which reduces friction and prevents soiling.

### Highlights:

- Extremely high gloss of the laminate for perfect photographic effect
- Full control over the lamination process thanks to the latest servo technology with tension control
- Inline with digital press for continuing production
- High speed for efficient converting
- More finishing options in compact construction: UV varnish, spot varnish and UV cold lamination
- Easy web access and maintenance for quicker support



# LA330 Advanced Laminator

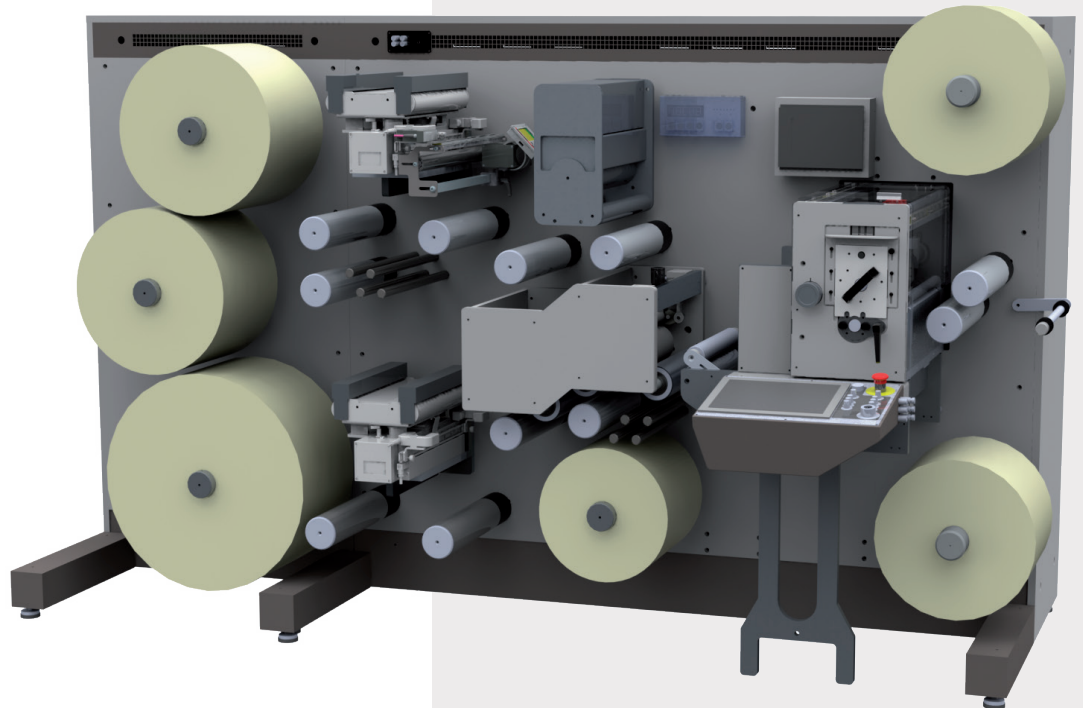

- *Use any substrate*
- *Laminate in register*
- *Automatic Slitting Station*

The **LA330** is a lamination and slitting combo machine. It runs as an offline unit as standard but can be fitted with a buffer and run inline with a digital press or other equipment. The **LA330** has separate tension control for unwind, lamination and rewind. As standard the process speed is 32m/min, but it can be configured to run up to 150m/min. The **LA330** has a soft-touch pressure nip with rubber on both anvil and pressure nip roller. This allows for wrinkle free lamination of everything for standard pressure sensitive labels to OPV solar cells.

The machine can operate both as a slitter-rewinder and as a laminating machine for self-adhesive laminate. It features a special rubber coated laminating nip that ensures curl/wrinkle free lamination.

The machine has an easy to use touch panel and features step-less electronic tension on both unwind and rewind spindles. A Fife web guide with ultrasonic sensor is fitted as standard. The web guide has a build-in splice table with two air-controlled clamps. There are many possible options to the machine; rotary knife box, razor blade system, inkjet head etc.

The rewinder is equipped with air expansion mandrels with sleeves easily exchangeable to other sizes. The rewinder can be set at rewinding label-in or label-out, and many functions are set and defined by touch display.

SPECIFICATIONS	METRIC	IMPERIAL
Web width	330 mm	13" (other sizes on request)
Speed	32 m/min	105 ft/min
	150 m/min on request	
Webguide	BST Ultrasonic	
Max unwind diameter	600 mm (800 mm optional)	23.6" (31.5" opt.)
Max rewind diameter	500 mm standard	19.7"
Rewind torque	10 - 100 Nm, adjustable on front panel	
Web tension press	5 - 20N, adjustable	
Max. roll size	Ø250 mm	9.8"
Dimensions (WxDxH)	2,0 x 1,3 x 1,7 m	



CO

OL

ART

ART

ART

RS

RS



# IC30

## Inline Coating system for HP Indigo

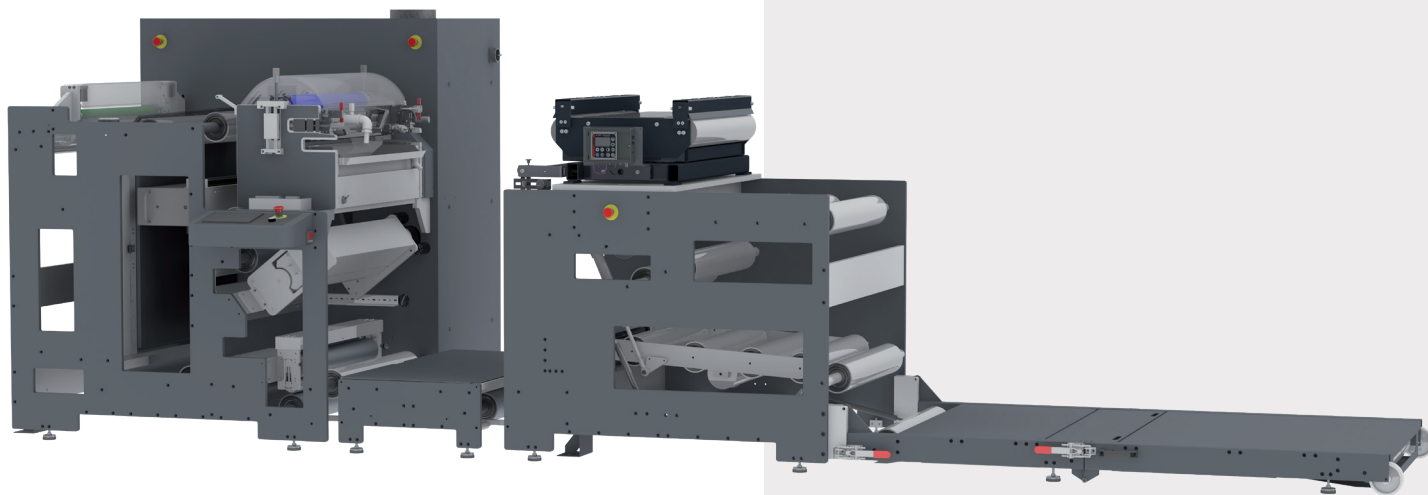

- *Designed for HP Indigo*
- *Fully modular wide web inline-coating system*
- *Water-based and UV varnish*
- *Optional sheeter*

The **GM IC30** is an innovative, inline or offline coating unit with optional selective coating solution for digital sheetfed folding Carton production. It is 100% modular and designed for perfect integration with the HP Indigo 20000 Digital Press. The **GM IC30** offers state-of-the-art coating. Both water-based and UV varnishes can be used for a wide range of applications, including pharmaceutical, media, food and confectionery, cosmetics, consumer electronics, promotional, gifts, and more. The IC30 and HP Indigo 20000 offer a complete digital printing folding carton production line – for printing, full surface or selective coating and stacking.

- Flexible, quick and self-cleaning sleeve-change over
- Enabling production of any size job from very small batches to large-scale production
- Optional sheeter and stacking modules

SPECIFICATIONS	METRIC	IMPERIAL
Web width	20 - 762 mm	7.9 - 30"
Substrate thickness	up to 550 µm	21.7 pt.
Max speed	55 m/min	108 ft/min
Webguide	BST Ultrasonic	
<b>Flexo Station</b>		
Print cylinder size option 1	228 - 482,5 mm	9 - 19"
Print cylinder size option 2	482,5 - 1016 mm	19 - 40"
Spot varnish option with registration and slow run		
Dimensions (WxDxH)	6,0 x 2,2 x 1,7 m	19.6 x 7.2 x 5.6 ft.

# EB30

## Integrated Coating Module with ebeam Curing

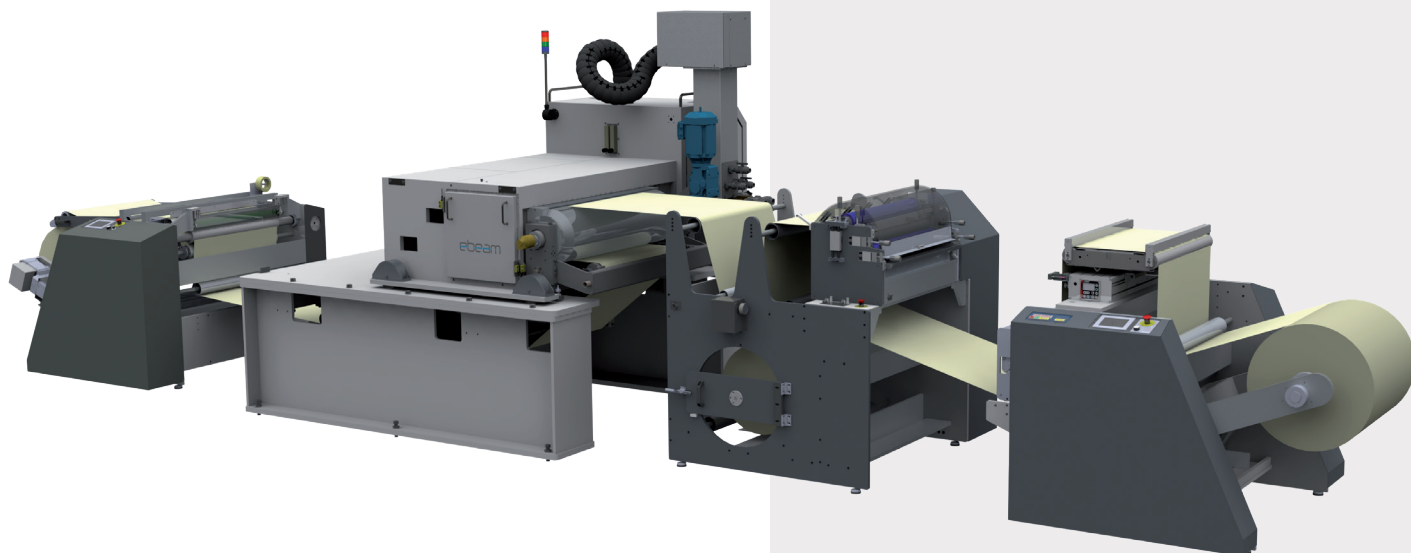

- *Designed for HP Indigo*
- *FDA compliant*
- *Food safe - ideal for flexible packaging*
- *Fully controlled curing process*
- *Best TCO on the market*

**EB30** is an integrated module that features an unwinder (LUW30) varnish/lamination station and a rewinder (LRW30) designed to run in-line with ebeam systems for curing a substrate. It is also designed as a stand-alone unwinder, varnish station and rewinder system. It is a microcontroller-controlled system that efficiently integrates its four component units and allows easy modification of the unit.

It has a user-friendly touch screen interface that allows the operator to operate the machine in an easy and efficient way. The machine has an enhanced taper tension control algorithm that ensures that excellent rolls are made.

- Outstanding ink protection and excellent gloss matte and soft-touch finishes
- Increased heat resistance enables heat sealing to form pouches
- No harmful photo initiators
- Cross-linking thin-film laminating adhesives
- Room temperature process, great for heat sensitive substrates
- High process efficiency: instant curing, no post-process storage needed

SPECIFICATIONS	METRIC	IMPERIAL
Web width	762 mm	30"
Substrate thickness	50 - 200 µm	2 - 8 pt.
Speed max.	72 m/min	236 ft
Max rewind diameter	500 mm	20"
Max rewind diameter	500 mm	20"
Core diameter	76,2 mm	3"
<b>Flexo Station</b>		
Varnishing roller	228 - 406 mm	9 - 19"
Spot varnish option with registration and slow run		
Length approx.	8,6 m	28 ft

# UC500L

## Coater with Lamination and Flexo Varnish

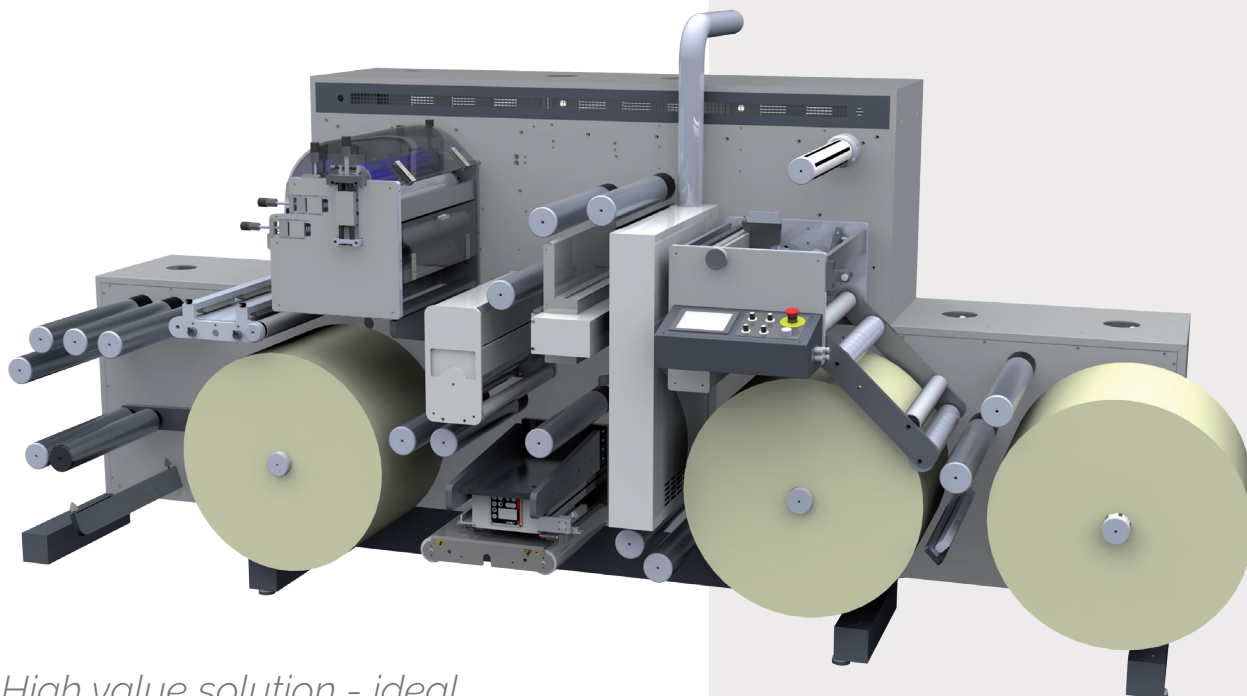

- *High value solution - ideal for banners, folders and post cards*
- *Maximum flexibility with UV and water-based varnish*

SPECIFICATIONS	METRIC	IMPERIAL
Web width	100 - 502 mm	4 - 20"
Substrate thickness	20 - 350 µm	0.8 - 13.8 pt
Max. web speed	30 m/min	98.4 ft
Max unwind diameter	700 mm	27.6"
Max rewind diameter	700 mm	27.6"
Max rewind diameter additional roll	800 mm	31.5"
Core diameter	76.2 or 152.4mm	3 or 6"
<b>Flexo Station</b>		
Print cylinder size	228 - 482,5 mm	9 - 19"
Spot varnish option with digital sensor register control and slow run		
<b>Slitting Station</b>		
Knife type	Pneumatic crush or razor knife	
Minimum distance crush	12,7 mm	0.5"
Dimensions of basic version	2,0 x 1,4 x 1,7 m	6.6 x 4.6 x 5.6 ft

Coater with lamination and flexo varnish. Single unit in-line or off-line converting for digital workflows. The converting line consists of a UV varnish and lamination/supergloss. Operation can be both inline with a dancer or offline (optional unwind module). Typical applications are banners, folders, post cards and roll-to-roll printed labels (not die cut). The line is operated by a touch display and available for web widths of 330mm (~13.0") or 515mm (~20.3").

**Optional equipment:**

- Separate unwind section, max. roll diameter 1000mm (~39.4")
- Hot-air module for water-based varnish
- Jogger table for sling stacking
- Spot varnish
- Corona treater
- Back scoring / Perforation

# UC500

## Universal Coating and Priming Unit

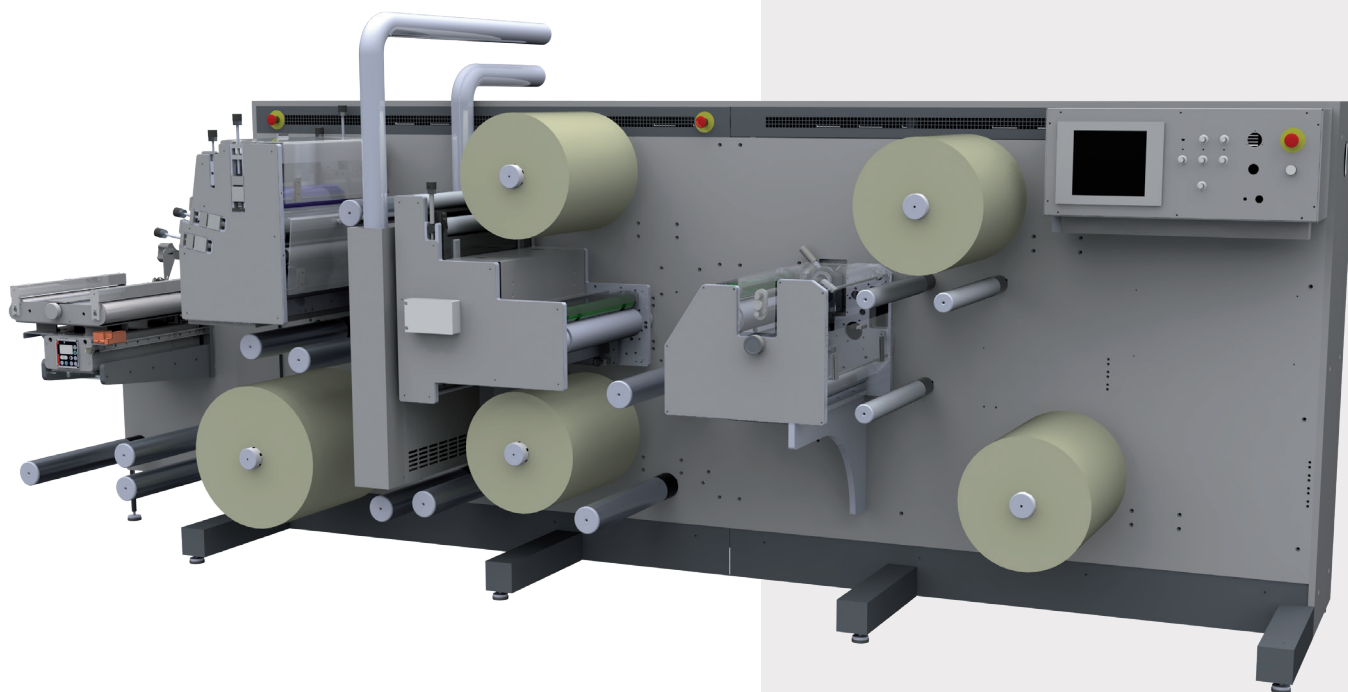

The **UC500** coating line is a universal coating/priming unit. It comes as an inline or offline version. Inline versions support all major digital presses. GM delivers the **UC500** in both left- right and right-left run direction. Coatings are applied with a flexo graphic station and can be both UV and water based. The **UC500** can be equipped with partial varnish, lamination, super gloss and other coating options. For priming synthetics, a Corona system is needed. Water based coatings will need a closed chamber option in most cases. The UC500 can be delivered in a "full duplex version" that applies coatings to both sides of the web. The standard 4x1,4 meters UC500 has a more compact sister: the ultra-compact UC500L. This light version measures only 2x1,4 meters.

### What it offers:

- UV flexo varnish
- Ultrasonic web guide
- Pneumatic 76mm spindles
- Dual 76mm rewind with Ø500mm capacity
- Optional hot-air for water-based varnish
- Touch display setting of label quantity per sheet and other job information
- Automatic register control adjusts for changes in the web speed (cut to mark)

SPECIFICATIONS	METRIC	IMPERIAL
Web width	100 - 502 mm	4 - 20"
Substrate thickness	60 - 200 µm	2.4 - 8 pt
Max. web speed	32 m/min	105 ft
<b>Flexo Station</b>		
Print cylinder size	228 - 1016 mm	9 - 40"
Spot varnish option with digital sensor register control and slow run		
<b>Slitting Station</b>		
Knife type	Pneumatic crush or razor knife	
Minimum distance crush	12,7 mm	0.5"
Dimensions (WxDxH)	3,9 x 1,4 x 1,7 m	12.9 x 4.4 x 5.4 ft

# DS330

## Inline Duplex Coating

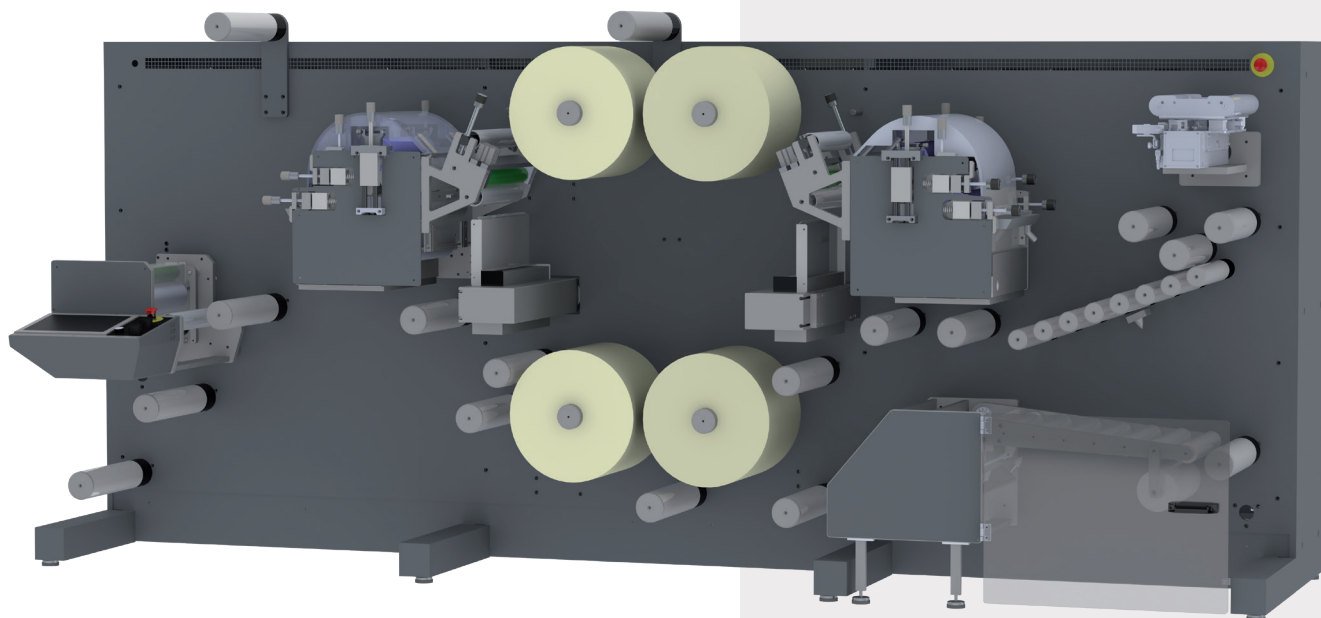

- *Designed for HP Indigo*
- *High-precision inline coating*
- *Combine matte, satin and gloss varnishes*
- *Cold foil effects*
- *Cast'n'cure holographic effects*

Designed for inline integration with the HP Indigo, the **GM DS330** includes two flexo units capable of applying spot, partial or full surface coating immediately after the printing stage. The unit is duplex providing protection to both sides of the web. The result is a seamless single-pass roll to roll print and coating operation, resulting in efficiency in logistics, minimum material waste, setup time and handling. Combination varnish printing with the DC330 opens numerous creative opportunities. Examples of possible effects include a double full-surface coat for extra protection, high-gloss varnish, optional cold foil or combining full, spot or line effects, thus creating contrast or adding vividness to an underlying colour. The **DS330** has a broad substrate range and high speed. It is capable of running 72m/min on substrates between 50 and 180gsm. The inline coater also features corona treatment, quick-change sleeve technology and the ability to switch from UV to water-based varnish within a few minutes.

SPECIFICATIONS	METRIC	IMPERIAL
Max web width	330 mm	13"
Substrate thickness	60 - 200 µm	2.4 - 8 pt
Max. web speed	72 m/min	236 ft
Flexo Station		
Printing width max	310 mm	12.2"
Print cylinder size	228 - 482,5 mm	9 - 19"
Spot varnish option with digital sensor register control and slow run		
Dimensions (WxDxH)	3,9 x 1,3 x 1,7 m	12.9 x 4.1 x 5.4 ft

CARD  
BOARD  
DEFINI  
SHIN  
G



# XP500

## Cardboard Finishing

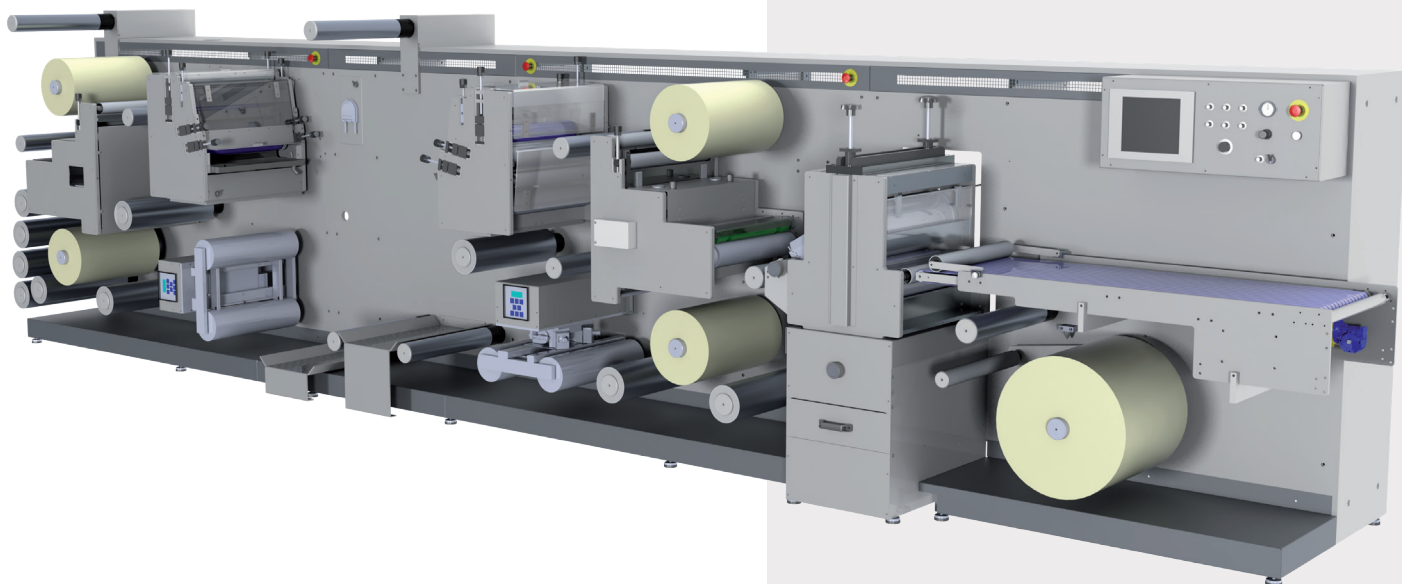

The **XP500** line is designed to varnish, laminate and die cut a 500 mm wide web on both sides in one process. It integrates with the Xeikon 5000 digital press and forms a full production line for post cards, brochures and many other products. The end product is placed on a conveyor or packed in boxes at the end of the line. Designed for postcards, tags, pocket folders and flyers the flexible magnetic die cutter offers many possibilities. As standard the line comes with a sling stacking system but more advanced systems can be added and customised with the exact applications you need:

- DUAL UV-flexo varnish
- Optional spot varnish with registration
- Super gloss varnish
- Cold foil silver, gold, and special effects.
- "Left to right" or "right to left" model possible
- Conveyor for sheet processing
- Can work as a rotary sheeter
- Quick job change with magnetic cylinder
- Runs with double tools for bending lines/folders
- Service friendly design requiring minimum maintenance

SPECIFICATIONS	METRIC	IMPERIAL
Web width	500 mm	20"
Substrate	80 - 500 µm	3.1 - 19.7 pt
Speed	Up to 72 m/min	Up to 236 ft/min
Die cut repeat range	50 - 558,8 mm	2 - 22"
Max unwind diameter	Ø1200 mm (external unw. option)	
Output to	Conveyor/stacker	
Lamination unwind diameter	Ø400mm	15.7"
Flexo cliché range (dual side)	228 - 482,6 mm	9 - 19"
Knife box	Shear, Crush or Razor	
Core diameter	76 mm	3"
UV system	GEW Air cooled	
Dimensions (WxDxH)	7,2 x 1,3 x 1,8 m	23.6 x 4.1 x 5.9 ft



# ETV330/515

## High Speed Sheeter



Roll to sheet guillotine cutter suitable for cutting labels and heavy materials. In-line and off-line operation. Builtin register control. A touch screen that allows for easy handling operates the sheeter. Cutting according to length, number of labels or print marks. It features a conveyor belt with stack and total counter. The web speed is limited to max. 30 m/minute and max. 14.000 sheets/hour and varies consequently according to the selected cutting length. The speed is typically 3.000 – 10.000 sheets/hour, subject to the job.

- Touch display setting of label quantity per sheet and other job information
- Cutting operations according to one of the following criteria:
  - Label intervals by photocell
  - Length measured by an encoder (1/10mm interval)
  - Print mark by a print mark read or capacitive sensor ("clear on clear"). (Optional equipment)
- Unwind mandrel with separate motor
- Conveyor belt with setting of sheets per stack and total number
- Automatic register control adjusts for changes in the sheeter speed
- Warning (and stop) when the unwinder is nearly empty
- Automatic stop in case of unintentional operation of the unwind section
- "Window detector" allowing for cutting jobs without register mark and for stop of the sheeter in case of missing label or matrix faults (1 lane)
- Suspension of cutting while unusable paper runs through the sheeter
- Switch-over from 1/10mm to 1/100inches when cutting by length
- When the sheeter is switched off, all settings are preserved (battery backup)
- Switch-over to inline operation (optional equipment)

SPECIFICATIONS	METRIC	IMPERIAL
Max. web width	330 or 515 mm	13 or 20.3"
Min. web width	30 mm	1.18"
Max. sheet length	10 m	33 ft
Min. sheet length	10 mm	0.4"
Max. web speed	30 m/min	98 ft/min
Max. speed in sheets	14 000 sheets/hour	
Core diameter	76,2 or 152,4 mm	3 or 6"
Max. unwind diameter (internal)	800 mm	31.5"
Cutting accuracy approx.	± 0,15 mm	± 0.006"
Max. roll weight, unwinding	150 kg	331 lb
Power / Air	200 - 240V+N+PE, 13A, 6 bar	
Dimensions ETV330 (WxDxH)	1,9 x 1,0 x 1,5 m	6.0 x 3.2 x 5.0 ft
Dimensions ETV515 (WxDxH)	1,9 x 1,1 x 1,5 m	6.0 x 3.7 x 5.0 ft

# HS30

## High Speed Rotary Sheeter



- *Designed for HP Indigo*

SPECIFICATIONS	METRIC	IMPERIAL
Web width	254 - 762 mm	10 - 30"
Substrate thickness	80 - 500 gsm	
<b>Die Station</b>		
Speed in analog mode	60 m/min	197 ft/min
"Repeat range "	508 - 1016 mm	20 - 40"
<b>Unwinder</b>		
Diameter max.	800 mm	31.5"
Max roll weight	700 kg	1543 lbs
Core diameter	76,2 mm	3"
<b>Rewinder</b>		
Diameter max.	400 mm	15.7"
Core diameter	76,2 mm	3"
<b>Flexo Station Option</b>		
Varnishing roller	Ø97.2mm / SH65	
Spot varnish repeat plate cylinder (optional)	305 - 482,6 mm	12 - 19"
<b>Slitting Station Option</b>		
Knife type	Pneumatic crush or razor	
Minimum distance crush	12,7 mm	0.5"
Dimensions (WxDxH)	4,8 x 1,9 x 1,7 m	15.7 x 6.2 x 5.6 ft

The **HS30** rotary sheeter is a cut-to-mark high-speed sheeter for 30" wide web. It is designed to convert roll-fed material into sheets. The size can be from 20" to 40" depending on tooling. Precision register is managed by servo drive technology. The **HS30** can deliver sheets to a conveyer or a stacker solution. The unwind station is a double sided hydraulic unwind stand with tension control and lift from floor function. Maximum diameter is 800 mm. The **HS30** is designed for easy integration with digital presses. Optional flexo coating unit is available.

COO

RE

CU

TTTE

RS

# PNT160S

## Semi-automatic Core Cutter



The **PNT160 Semi-automatic Core Cutter** provides high precision feeding and cutting of cardboard cores of optional length and sizes at high speeds. Long experience in the manufacturing of core cutters has resulted in the development of a unique product giving high priority to service friendliness and production speed. The switchover from job to job is easily done within a few minutes. The core cutter is operated by a user-friendly touch display with graphic symbols. The PNT160 automatically adjusts all machine operations to the selected core size and wall thickness.

SPECIFICATIONS	METRIC	IMPERIAL
Cutting speed (depending on core size and material)	Max. 40 - 70 cuts/min	
Cardboard core diameters	12,7 - 152,4 mm	0.5 - 6"
One adapter set needed for each diameter		
Material thickness	Max. 15 mm	0.59"
Air supply	Min. 4 bar	
Electricity supply	200 - 240V+N+PE, 13A	
Dimensions (WxDxH)	2,5 x 0,5 x 1,6 m	

# P16LC

## Manual Core Cutter

The **P160LC** is a manual entry-level and easy to use core cutter designed with low price in mind. Despite its low price it is still compatible with the tooling on the bigger PNT/PNTS models. This means that adapters can be reused in case of an upgrade.

- Sensor making the initial cut unnecessary
- Basic machine includes one 3" / 76 mm adapter and anvil
- Simple robust design ensures easy service and long lifespan
- Nylon anvil prolongs knife life
- Build-in ruler makes cutting length adjustment quick and easy
- Integrated safety handle keep operators hands away from knife blade
- Cutting of cores with a diameter from 12.7 up to 153 mm (6") and a wall thickness of up to 15 mm (0.6")



SPECIFICATIONS	METRIC	IMPERIAL
Cutting speed	Up to 10 cuts/min, subject to core size and material	
Core diameter	12.7 - 152.4 mm	0.5 - 6"
One adapter set needed for each diameter		
Core length	Up to 1600 mm	Up to 63"
Material thickness	Up to 15 mm	Up to 0.59"
Power	3x400V+PE, 10A	
Dimensions	1.9 x 0.5 x 1.5 m	

ROLL  
HAND  
LING  
EQUIP  
MENT

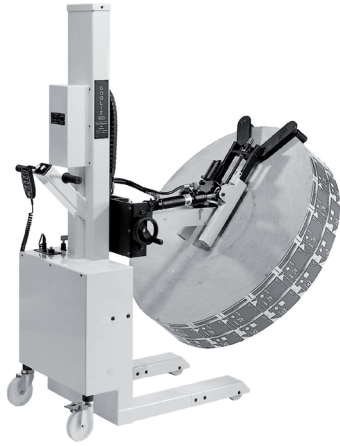

## KU200

### Electro-Hydraulic Roll Lifter

Mobile electric/hydraulic roll lifters/roll turners. All models are available with remote control and are equipped with an expansion mandrel and a roll holder preventing telescoping of the roll. Max. roll weight 200 kg. A laterally movable lever arm is standard on the **KU200**.

#### SPECIFICATIONS

Max. lifting height	1450 - 1750 mm *
Max. clearance height	1240 - 1540 mm *
Max. roll diameter	900 - 1100 mm *
Min. roll diameter	360 mm
Min - max. roll width	160 - 330 mm
Max. roll weight	200 kg
Lifts per charge	>200
Core diameter	76 mm (3")
Expansion mandrel	Yes
Roll clamp	Double
Turning motor	Hydraulic
Laterally moverable arm	Yes
Motorized	No
Battery charger	Built-in
Energy meter	Yes
Battery [Ah]	2x12V/40Ah
Dimension (HxWxL)	1,8 x 0,5 x 1,5 m
Weight	245 kg (539 lbs)

\* depends on the model



## KU350DHF

The **KU350DHF** is an electric/hydraulic roll lifter/roll turner enabling rolls to be taken down from a pallet, turn them from horizontal into vertical position and place them either on the floor or directly in the rewind/unwind section of a machine.

#### SPECIFICATIONS

Min - max roll diameter	400 - 1300 mm
Min - max roll width	160 - 500 mm
Max. roll weight	350 kg
Lifts per charge	>200
Core diameter	76 mm (3")
Expansion mandrel	Yes
Roll clamp	Double
Turning motor	Hydraulic
Laterally moverable arm	Yes
Motorized	No
Battery charger	Built-in
Energy meter	Yes
Battery [Ah]	2x12V/40Ah
Dimension (HxWxL)	2,0 x 0,8 x 1,6 m
Weight	500 kg (1100 lbs)

## RL Roll Turner

A simple, practical and cost efficient roll turner available with various options. Designed for mounting on a crane or similar. GM offers smaller roll turners as well.



#### SPECIFICATIONS METRIC IMPERIAL

Max. roll diameter	1240 mm	49"
Min. roll diameter	660 mm	26"
Max. roll weight	300 kg	661 lbs
Shaft	76 or 152 mm	3 or 6"



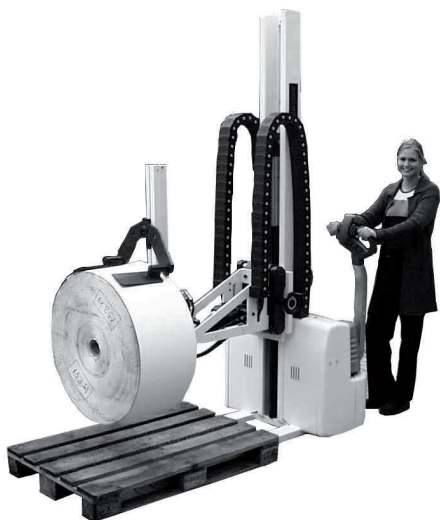

### KU350DHFM

The **KU350DHFM** is a motorised roll lifter/roll turner that can lift rolls from a pallet, turn them from horizontal into vertical position and place them either on the floor or directly in the rewind/unwind section of a machine.

#### SPECIFICATIONS

Lifting height	2180 mm
Clearance height	1890 mm
Min - max roll diameter	400 - 1300 mm
Min - max roll width	160 - 500 mm
Max. roll weight	350 kg
Lifts per charge	>200
Core diameter	76 mm (3")
Expansion mandrel	Yes
Roll clamp	Double
Turning motor	Hydraulic
Laterally moverable arm	Yes
Motorized	Yes
Battery charger	Built-in
Energy meter	Yes
Dimension (HxWxL)	2,4 x 0,8 x 1,6 m
Weight	500 kg



### KU600 Electro-hydraulic Roll Lifter

The **KU600** is a motorised roll lifter/roll turner enabling rolls to be taken down from a pallet, turn them from horizontal into vertical position and place them either on the floor or directly in the rewind/unwind section of a machine.

#### SPECIFICATIONS

Lifting height	2900 mm
Min - max roll diameter	540 - 1260 mm
Max roll width	600 mm
Max. roll weight	600 kg
Lifts per charge	>100
Core diameter	70 - 76 mm (2.8 - 3")
Expansion mandrel	Yes
Roll clamp	Double
Turning motor	Hydraulic
Laterally moverable arm	Yes
Motorized	Yes
Battery charger	Built-in
Energy meter	Yes
Dimension (HxWxL)	2,4 x 0,8 x 1,8 m
Weight	1000 kg



### RL Roll Lifter

Mobile lifting units for handling of paper rolls. The RL-line includes four models with different lifting heights and manual or automatic lifting. The legs of the lifter fit under a standard EU pallet. Both hydraulic and electric models are available.

#### SPECIFICATIONS      METRIC      IMPERIAL

Lifting height	100 - 1500 mm	3.9 - 59"
Max. roll weight	160 - 350 kg	352 - 770 lbs
Lifting system	Electric or manual hydraulic foot pump	
Weight	80 - 110 kg	176 - 242 lbs



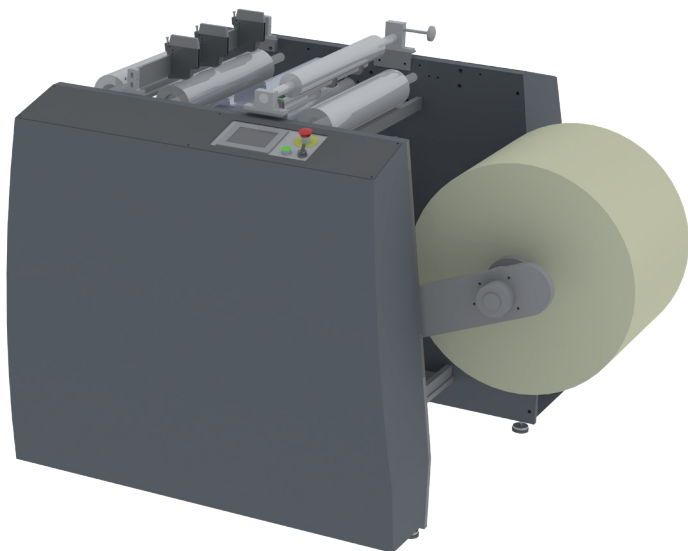

### LRW500 - Rewind Unit

For the heaviest and most demanding jobs, GM offers this multi-purpose, stand-alone rewinding unit with splice table, web guide and slitting knife. The entire module is electronically synchronized and capable of communicating with a variety of printing systems.

SPECIFICATIONS	METRIC	IMPERIAL
Web width	500 mm	19.7"
Max. roll diameter	1200 mm	47.2"
Max. roll weight	750 kg	1653 lbs
Max. speed	30 m/min	98 ft/min
	higher on request	
Substrate support	40 - 350 gsm paper and film	

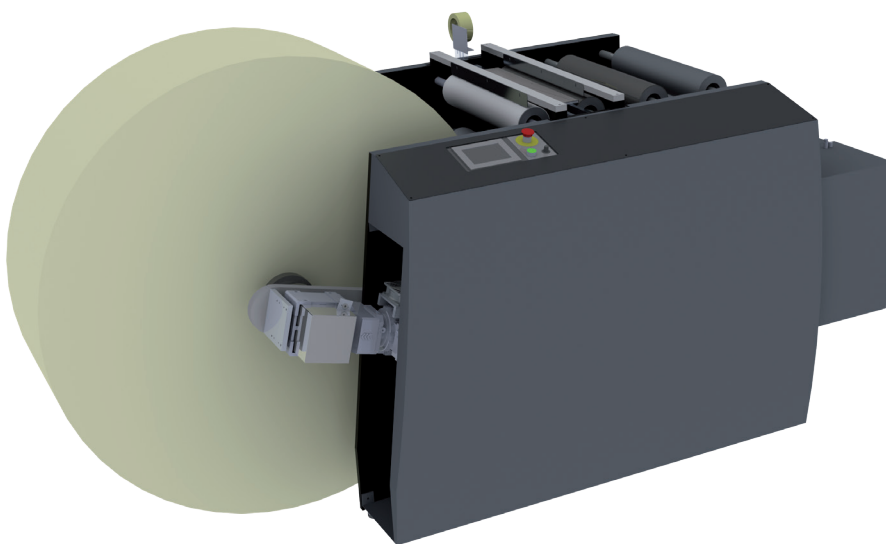

### LUW500 - Unwind Unit

For the heaviest and most demanding jobs, GM offers this multi-purpose, stand-alone unwinding unit with splice table, web guide and slitting knife. The entire module is electronically synchronized and capable of communicating with a variety of printing systems. Unit has a low unwind signal for press.

SPECIFICATIONS	METRIC	IMPERIAL
Web width	500 mm	19.7"
Max. roll diameter	1500 mm	59"
Max. roll weight	750 kg	1653 lbs
Max. speed	30 m/min	98 ft/min
	higher on request	
Substrate support	40 - 350 gsm paper and film	

WASTE  
REMO  
VAL  
AND  
SHRE  
DDER  
UNITS

## GR80

Shredder without own suction. Designed to shred a wide range of materials and reduce it to approx. 5 - 10% of the original volume.

SPECIFICATIONS	METRIC	IMPERIAL
Max. trim width	30 mm	1.2"
Max. trim extraction speed	200 m/min	656 ft/min
Connection tube diameter inlet int/ ext dimensions	63/75 mm	2.5/3"
Dimensions (WxDxH)	0,6 x 0,5 x 1,1 m	2 x 1.7 x 3.6 ft



## GR80K

Shredder with built-in waste removal unit. Designed to shred a wide range of material and reduce it to approx. 5 - 10 % of the original volume.

SPECIFICATIONS	METRIC	IMPERIAL
Max. trim width	30 mm	1.2"
Max. trim extraction speed	250 m/min	820 ft/min
Connection tube diameter inlet int/ ext dimensions	2x56 / 2x63 mm	
Dimensions (LxWxH)	0,7 x 0,7 x 0,9 m	2 x 2 x 3 ft



## SU3 - Waste Removal Unit

The **SU3 Waste Removal Unit** is an inline shredder for slitting applications, designed to convey trim from slitters of almost any make to a waste bin. The SU3 is mounted on wheels and is easily moved from one machine to another.

SPECIFICATIONS	METRIC	IMPERIAL
Max. trim width	20 mm	0.8"
Max. trim extraction speed	150 - 200 m/min	492 - 656 ft/min
Dimensions (LxWxH)	0,6 x 0,4 x 0,6 m	
Weight	35 kg	77 lbs



SO

LA

R



# SOLAR

## Coating Platform

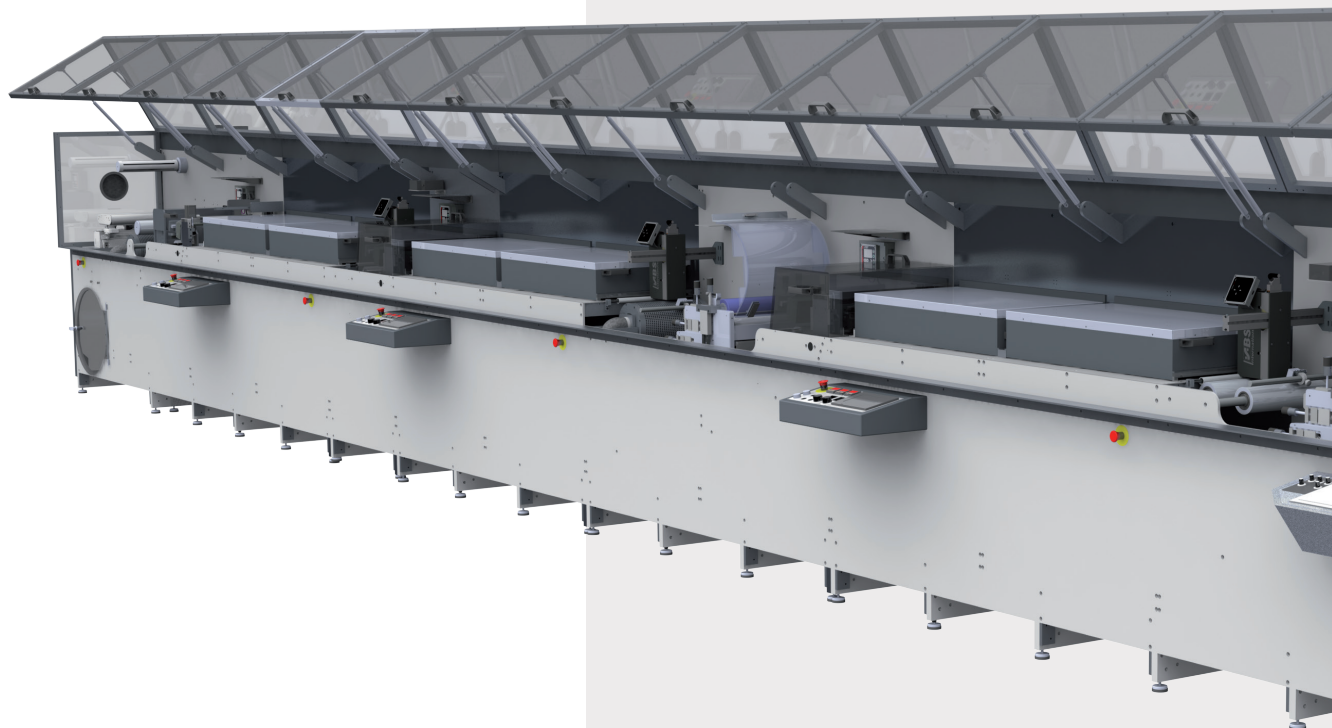

The **Solar** is the result of years of experience with OPV solar coating machinery. It is an R&D machine with industrial output capacity. With this machine your research team can get the best of two worlds and experiment with future coatings. The machine is designed to work with organic, perovskite and other related PV technologies, OLED, LEC and many more.

### Specifications:

- Web width: 330/500/550 mm (13"/20"/22"). Custom size possible
- Speed from 0.01 m – 32 m/min. Up to 120 m/min on request
- Individual printing stations: Flexographic, flatbed or rotary screen printing and multiple slot-die coating
- DTU OPV Slot-die coating head 330 mm with Knauer & Kreutzberg high pressure ink pump system
- Corona treater from Vetaphone
- Double sided ECO Web cleaning from Teknek Ltd
- Pneumatic unwind/rewind spindles 3 or 6" (other sizes on request)
- Splice table with pneumatic clamps and ultra-sonic web guidance
- Based on industry quality components Servo driven for smooth web transport with closed loop tension control
- 2 meters drying tunnel through a double pass hot-air/IR oven (can be extended through multiple ovens)
- Semi-cantilevered design for high stability and high-res accuracy. Easy web access and maintenance
- Build-in remote access via internet with self-diagnostics

### COST EFFECTIVE

The SOLAR coater is cost-effective because the entire design is based on modified versions of components from our high volume R2R finishing series of machines

### DESIGNED FOR RESEARCH AND START-UP PRODUCTION

The SOLAR addresses the challenges associated with roll-to-roll equipment in R&D environments. It can be made with enclosures limiting safety-issues and support option in machine atmosphere control.

### USABILITY

A large color touch screen provides the operator with an easy machine overview. The use of graphical symbols and animations makes the machine easy to learn and use. A remote internet hook up can be used for remote support.

### PLAN FOR THE FUTURE

The modular built SOLAR makes future addition of print / treatment stations simple and fast. A fully digital servo drive line eliminates traditional drive shafts. An extra station can be added by connecting wires – not mechanics. The software platform is modular as well. Interface to existing or future data collection system is foreseen.



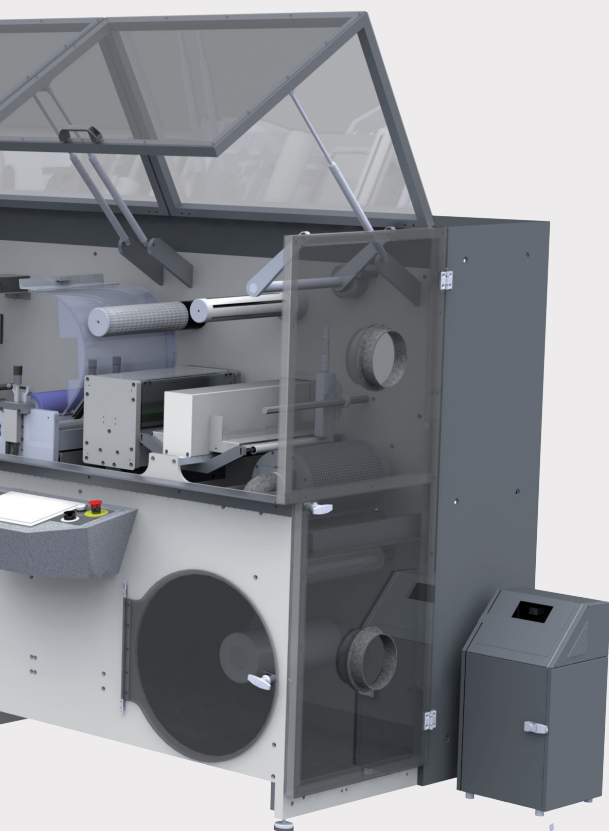

**DEVELOPED  
IN COOPERATION  
WITH THE  
DANISH TECHNICAL  
UNIVERSITY**

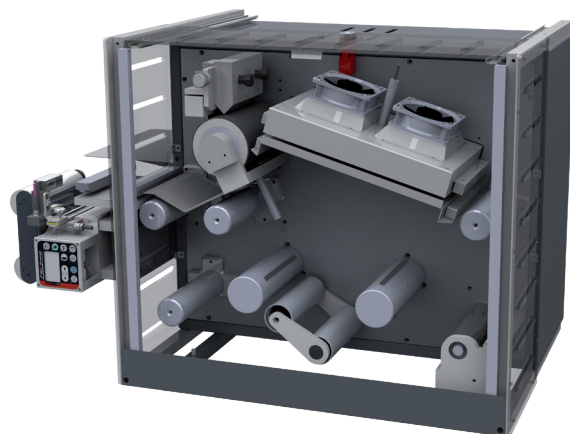

**STORE YOUR DATA**

The coater is based on a digitally controlled platform. The optional data logger can store and print important data like speed, temperature, active printing stations. The web can also be time stamped with the addition of an inkjet-head.

**BROAD RANGE OF COATING STATION**

The SOLAR supports multiple coating and printing methods. Slot-die is mandatory on most OPV equipment; but also SCREEN and FLEXO is supported as standard modules.

**CONFIGURATION**

Unwind with 3" shaft, ultra-sonic edge guide, Web cleaning, Corona treater, Slot-die head, Flexographic printing station with register, Screen printing with register, Lamination unit, Hot air and IR ovens, Servo loop tension control, Rewind with 3" shaft.

Many special options like; Laser die cutter, Rotary die cutter, Video Inspection, VUV or UV curing, cold foiling, hot foiling and start-stop robot web manipulation.

**LRN15M - Mini Roll to Roll**

The LRN15M mini roll to roll (R2R) coater from Grafisk Maskinfabrik is an easy to use entry platform for multipurpose OPV/other coating.

Developed in cooperation with the Danish Technical University to mimic processing in a roll-to-roll machine without the high material consumption and upstart time requirements. It is a hands-on, precision instrument for slot-die coating any solution-processable material onto flexible substrates.

SPECIFICATIONS	METRIC	IMPERIAL
Web width	10 - 150 mm	0.4 - 5.9"
Substrate	50 - 200 µm	2 - 8"
Max. unwind diameter	240 mm	9.5"
Unwind core diameter	76,2 or 152,4 mm	3 or 6"
Max. rewind diameter	240 mm	9.5"
Rewind core diameter	76,2 or 152,4 mm	3 or 6"
Dimensions (WxDxH)	1,1 x 0,7 x 0,7 m	

# Configuration examples

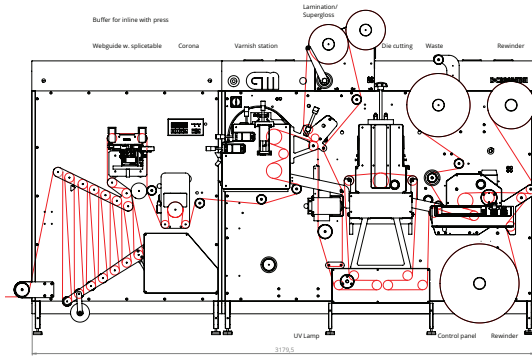

**DC330MINI** finishing line with inline option for HP Indigo digital press. This configuration offers compact and economic processing of labels. Features: flexo varnish, lamination, spot varnish and semi-rotary die cutting.

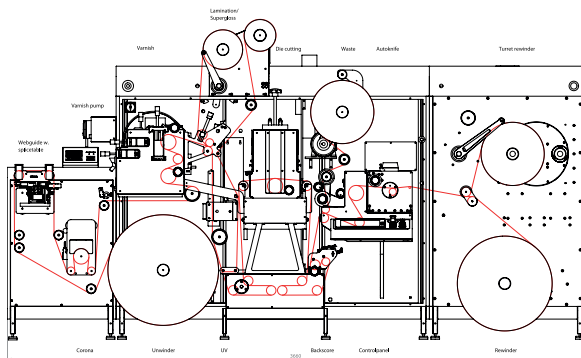

**DC330MINIflex** finishing line with the powerful smart essential options. Compact and economic processing of labels with flexo varnish, lamination, spot varnish, semi-rotary die cutting, autoslitting and semi automatic turret rewriter

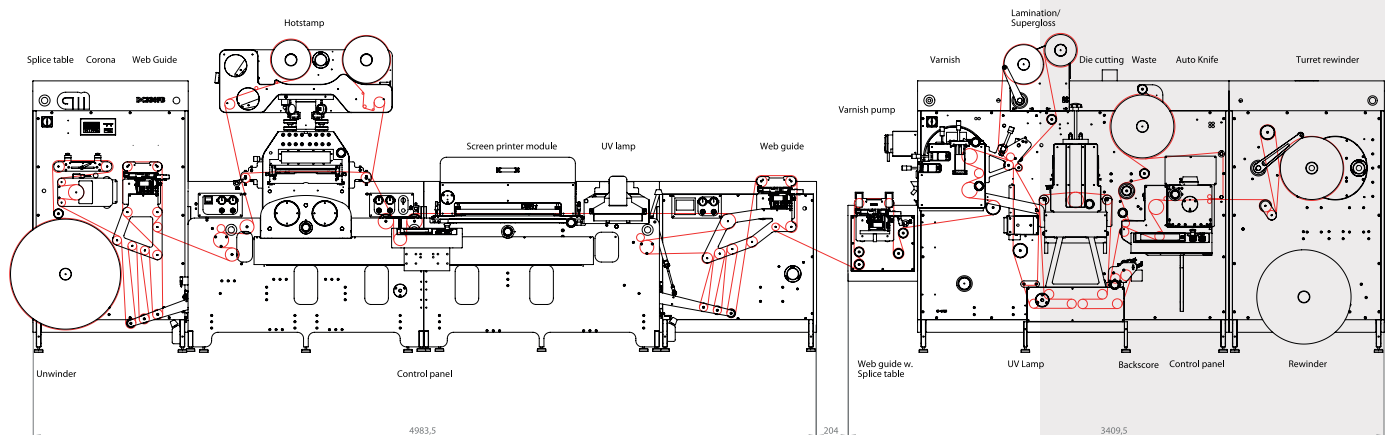

**330FB** Premium Wine Label Finisher inline with **DC330MINIflex**. High quality 50-ton flatbed foil stamping and flatbed screen printing with servo register and foil saver. Embossing and hot foiling can be done using the same tool. DC330MINIflex expands the finishing potential with flexo varnish, lamination, spot varnish, semi-rotary die cutting, autoslitting and rewinding on semi automatic turret rewriter.

**DC330MINIflex** finishing line with two flexo varnish stations. Additional modules are lamination, spot varnish, semi-rotary die cutting and slitting.

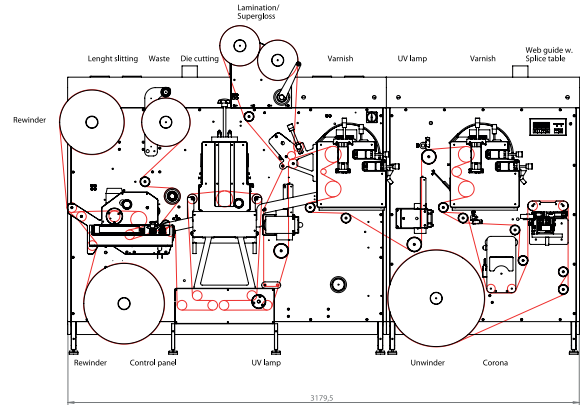

**DC330HYBRID** finishing line. Hybrid laser and traditional die cutting. Flexo varnish with spot, lamination, coldfoiling, semi-rotary die cutting, slitting and dual rewind.

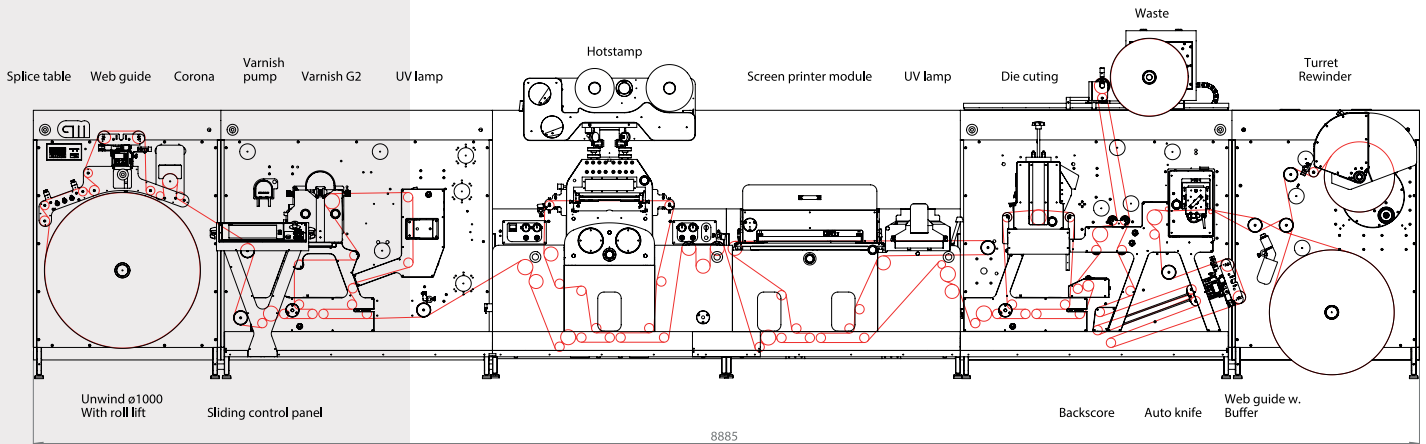
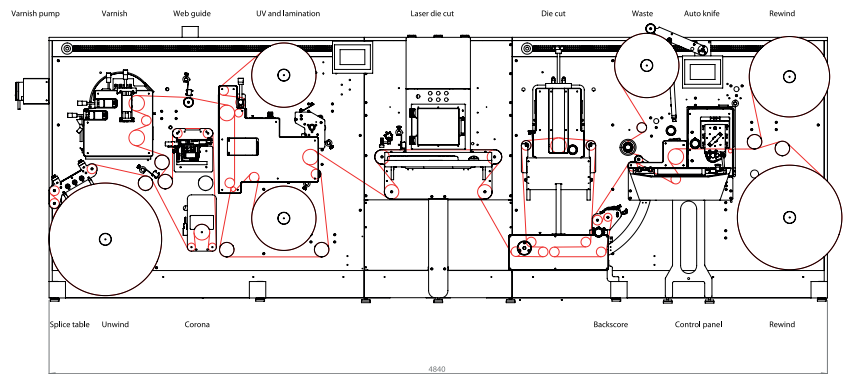

**DC350** finishing line with combined 50-ton high quality flatbed hot foil stamping and flatbed screen printing. In addition semi-rotary GM SmartFlexo, semi-rotary die cutting, GM SmartStrip, GM SmartSlit and GM SmartTurret - NEW fully servo controlled automatic turret rewinder.

**Grafisk Maskinfabrik A/S**  
Bregnerødvej 92  
DK-3460 Birkerød, Denmark  
Phone: +45 4581 2300  
[gm@gm.dk](mailto:gm@gm.dk) | [www.gm.dk](http://www.gm.dk)

---

CO  
VE  
TI  
MA  
EA

**“Converting made easy”**

Specifications and terms are subject to change without notice. Grafisk Maskinfabrik is a registered trademark. All other product and brand names are trademarks and/or registered trademarks of their respective companies. GM disclaims any and all rights in these marks. Copyright 2019, Grafisk Maskinfabrik A/S. For more information, please visit [www.gm.dk](http://www.gm.dk)